

PARTS CATALOGUE

BR250TK (8BDC) CANADA, JAPAN



1D8BD-100E1

(2D8BD-100E1)

A2

BR250TK
PARTS CATALOGUE
©2004 by Yamaha Motor Co., Ltd.
1st edition, May 2004
All rights reserved.
Any reprinting or unauthorized use
without the written permission of
Yamaha Motor Co., Ltd.
is expressly prohibited.
Printed in Japan.

A3

BR250TK



FOREWORD

This Parts Catalogue is related to the parts for the model(s) on the cover page. When you are ordering replacement parts, please refer to this Parts Catalogue and quote both part numbers and part names correctly.

1. Modifications or additions which have been made after the issue of the Parts Catalogue will be announced in the Parts News.

It is advisable that you make the necessary corrections to the Parts Catalogue according to the Parts News.

2. Abbreviations

The following abbreviations are used in this Parts Catalogue.

“UR” Use specified parts number.

“UN” Use as many as needed.

“AP” Alternate Parts

“LM” Locally Made (Parts need to be ordered locally)

“F#” Frame No. (Applicable machine No.)

“O/S” Over Size

3. The number of components for assembly

- Parts, which are to be supplied in an assembly, are listed with a dot (.) in front of the part name as shown below.
- The numeral appearing to the right of each component part indicates the quantity of parts for each assembly unit.

PART NO.	DESCRIPTION	Q'TY	REMARKS
2F5-83310-60	FRONT FLASHER LIGHT ASSY	2	
115-83311-60	.BULB (6V-18W)	1	

4. Applicable colours of graphics are represented in the “REMARKS” as shown below.

PART NO.	DESCRIPTION	Q'TY	REMARKS
2N4-24110-00-X5	FUEL TANK COMP.	2	MXR
3J1-24240-10	.GRAPHIC, FUEL TANK	1	FOR MXR

5. Note that the illustrations for reference in finding parts numbers are not to be used for assembling. When assembling, please use the applicable service manual.

6. The asterisk (*) before a reference number indicates modified items after the first edition.

FOREWORD

7. Applicable Serial No.

Engine Serial No.

Frame Serial No.

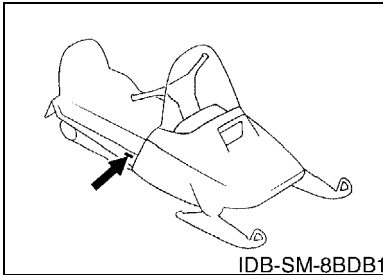
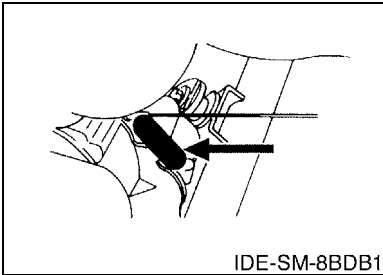

10. Applicable Starting Serial No.

Frame Serial No.

Serial No.	Name Of Q'ty Column	Model Code
JYE8BD0085A035899	CAN	8BDC
	JPN	8BDC

8. Applicable Colour Code (The (*) mark shows Model colour.)

Abbreviation	Colour Name	Colour Code
DCM2(*)	DARK CYAN METALLIC 2	0337

9. Quantity Column Information

Column No.	Name Of Q'ty Column	Destination
1	CAN	CANADA
2	JPN	JAPAN

CONTENTS

ENGINE

CYLINDER	B2
CRANKSHAFT & PISTON	B3
AIR SHROUD & FAN	B4
OIL PUMP	B5
PUMP DRIVE GEAR	B6
INTAKE	B7
CARBURETOR	B9
EXHAUST	B11
CRANKCASE	B12
STARTER	B13

DRIVE

PRIMARY SHEAVE	B14
SECONDARY SHEAVE	B15

BODY

ENGINE BRACKET	C2
OIL TANK	C3
FRAME	C4
SKI	C6
STEERING	C8
STEERING GATE	C9
FUEL TANK	C10
FUEL TANK 2	C11
SEAT	C13
BRAKE	C14
CONTROL CABLE	C15
TRACK SUSPENSION 1	D2
TRACK SUSPENSION 2	D4
TRACK DRIVE 1	D7
TRACK DRIVE 2	D8
EMBLEM	D10
SHROUD & WINDSHIELD	D11
GUARD & LUGGAGE BOX	D13
BUMPER	D14
INSTRUMENT PANEL	E2

ELECTRICAL

GENERATOR	E3
METER	E4
HEADLIGHT	E5

TAILLIGHT	E6
HANDLE SWITCH & LEVER	E7
ELECTRICAL 1	E8
ELECTRICAL 2	E9
ALTERNATE REAR VIEW MIRROR	E10
ALTERNATE THUMB WARMER KIT	E11
ALTERNATE REBUILD KIT	E12
ALTERNATE CLUTCH TUNE UP KIT	E13

INDEX

NUMERICAL INDEX	M1
-----------------------	----

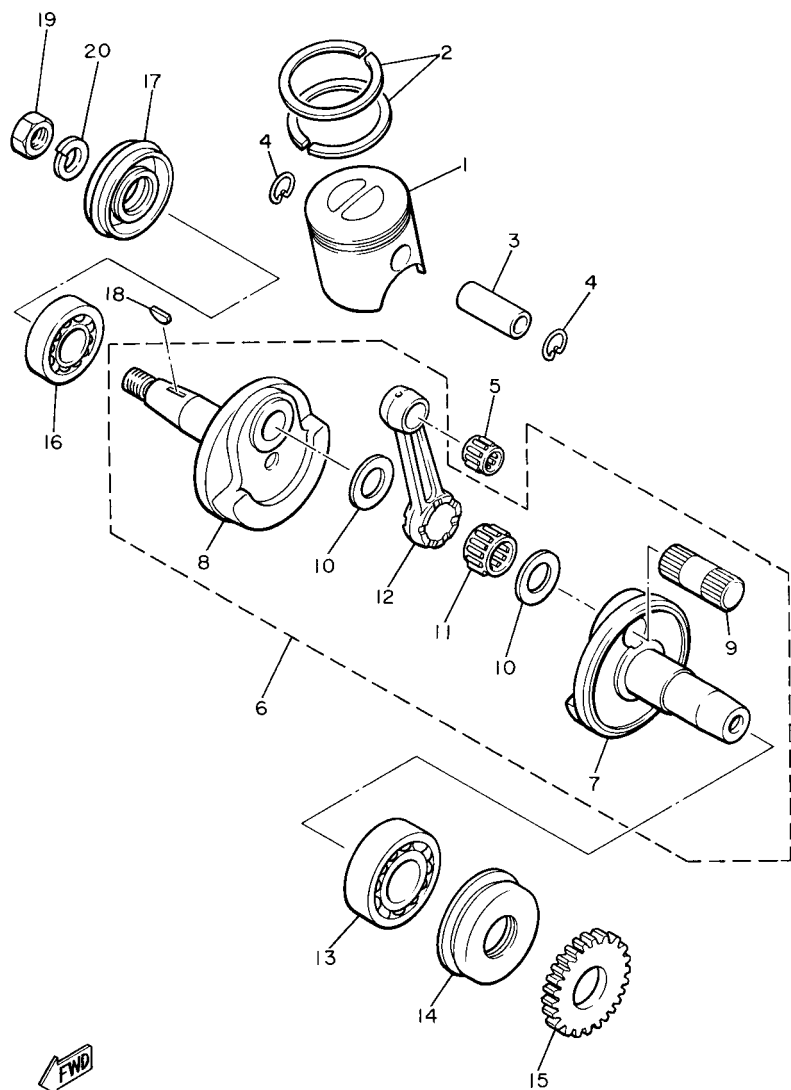

8R4100-2021

FIG. 2 CRANKSHAFT & PISTON

REF. NO.	PART NO.	DESCRIPTION	CAN	JPN				REMARKS
1	8R4-11631-00-96	PISTON (STD)	1	1				
	8R4-11635-00	PISTON (0.25MM O/S)	1	1				AP
	8R4-11636-00	PISTON (0.50MM O/S)	1	1				AP
2	8R4-11610-00	PISTON RING SET (STD)	1	1				
	8R4-11610-10	PISTON RING SET (0.25MM O/S)	1	1				AP
	8R4-11610-20	PISTON RING SET (0.50MM O/S)	1	1				AP
3	818-11633-00	PIN, PISTON	1	1				
4	93450-20026	CIRCLIP	2	2				
5	93310-218A6	BEARING	1	1				
6	8R4-11400-00	CRANKSHAFT ASSY	1	1				
7	8R4-11412-00	.CRANK 1	1	1				
8	8R4-11422-00	.CRANK 2	1	1				
9	8F3-11681-00	.PIN, CRANK 1	1	1				
10	90209-24183	.WASHER	2	2				
11	93310-424E8	.BEARING	1	1				
12	8R4-11651-00	.ROD, CONNECTING	1	1				
13	93306-30623	BEARING	1	1				
14	93102-30326	OIL SEAL	1	1				
15	8R4-13178-00	GEAR, PUMP DRIVE	1	1				
16	93306-30555	BEARING	1	1				
17	93102-25183	OIL SEAL	1	1				
18	90280-05013	KEY, WOODRUFF	1	1				
19	90170-16425	NUT	1	1				
20	92907-16100	WASHER	1	1				

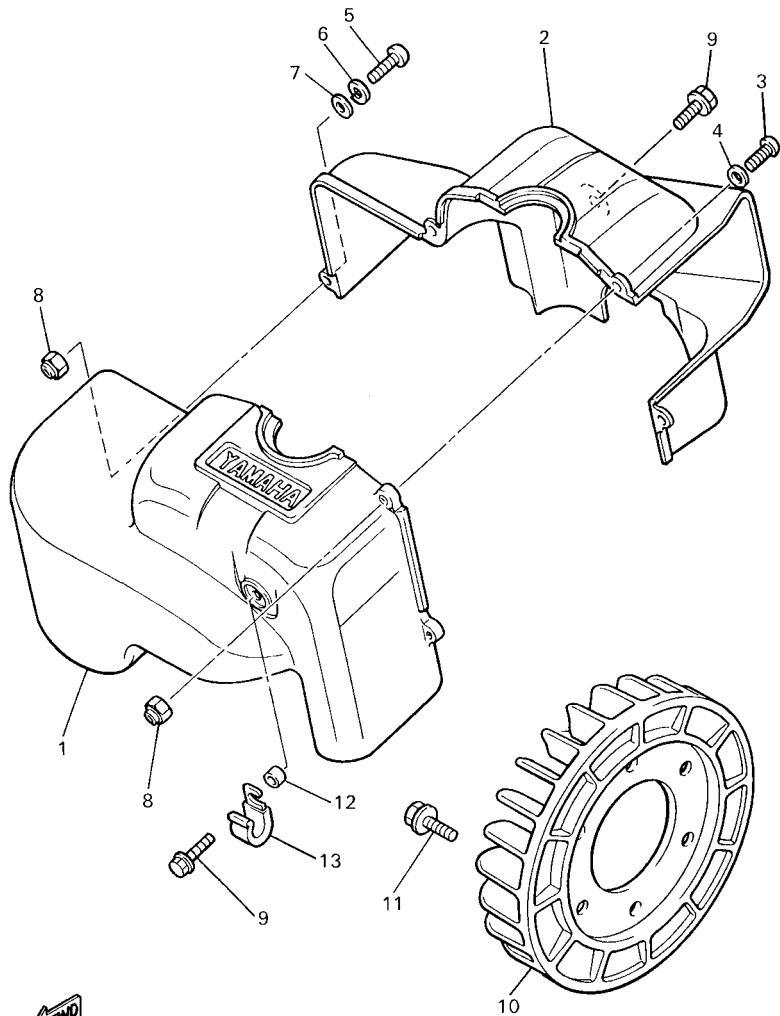

8BD100-6030



FIG. 3 AIR SHROUD & FAN

REF. NO.	PART NO.	DESCRIPTION	CAN	JPN	REMARKS
1	8R4-12651-03	AIR SHROUD, CYLINDER 1	1	1	
2	8R4-12652-02	AIR SHROUD, CYLINDER 2	1	1	
3	98507-05020	SCREW, PAN HEAD	3	3	
4	92907-05600	WASHER, PLATE	3	3	
5	98507-05030	SCREW, PAN HEAD	1	1	
6	92907-05100	WASHER, SPRING	1	1	
7	92907-05600	WASHER, PLATE	1	1	
8	95707-05300	NUT, FLANGE	4	4	
9	90119-06108	BOLT, WITH WASHER	2	2	
10	8G8-12611-01	FAN	1	1	
11	90105-06556	BOLT, FLANGE	6	6	
12	90387-066K1	COLLAR	1	1	
13	90465-10313	CLAMP	1	1	

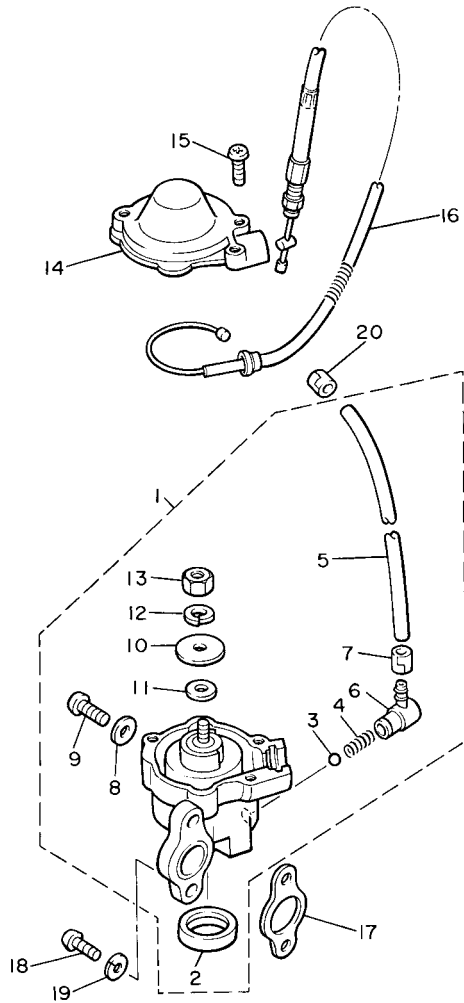

80F100-5040

FIG. 4 OIL PUMP

REF. NO.	PART NO.	DESCRIPTION	CAN	JPN			REMARKS
1	81E-13101-01	OIL PUMP ASSY	1	1			
2	90338-21075	.PLUG	1	1			
3	93505-32002	.BALL	1	1			
4	90501-02217	.SPRING, COMPRESSION	1	1			
5	90446-08201	.HOSE	1	1			
6	353-13552-01	.NOZZLE	1	1			
7	90468-02025	.CLIP	1	1			
8	90430-04004	.GASKET	1	1			
9	98907-04008	.SCREW, BIND	1	1			
10	137-13138-01	.PLATE, ADJUSTING	1	1			
11	137-13137-00-03	.SHIM (T=0.3)	1	1			UR UN
	137-13137-00-05	.SHIM (T=0.5)	1	1			UR UN
	137-13137-00-10	.SHIM (T=1.0)	1	1			UR UN
12	92907-05100	.WASHER, SPRING	1	1			
13	95307-05600	.NUT	1	1			
14	8A5-13146-01	COVER, ADJUST PULLEY	1	1			
15	98507-04018	SCREW, PAN HEAD	3	3			
16	81E-26320-00	PUMP CABLE ASSY	1	1			
17	8Y0-13116-01	GASKET, PUMP CASE	1	1			
18	98507-05016	SCREW, PAN HEAD	2	2			
19	92907-05100	WASHER, SPRING	2	2			
20	90468-02025	CLIP	1	1			

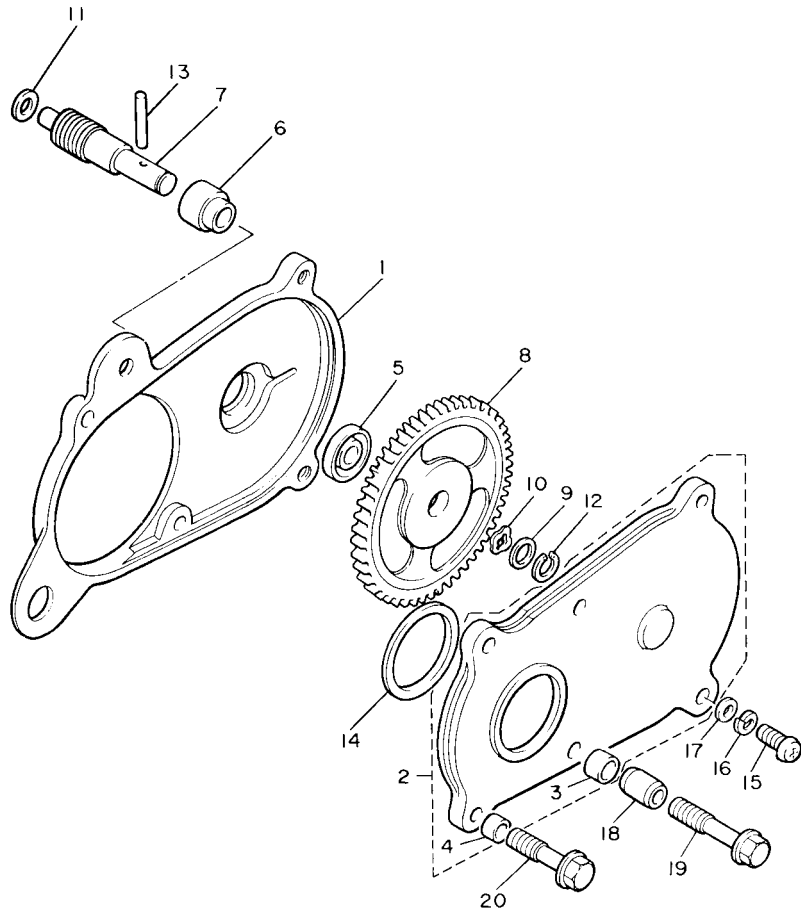

87P171-0050

FIG. 5 PUMP DRIVE GEAR

REF. NO.	PART NO.	DESCRIPTION	CAN	JPN				REMARKS
1	8R4-15416-00	COVER, OIL PUMP	1	1				
2	8R4-15426-00	COVER, OIL PUMP 2	1	1				
3	90387-082N1	.COLLAR	2	2				
4	90387-062N2	.COLLAR	2	2				
5	93101-10001	OIL SEAL	1	1				
6	821-13176-00	METAL, WORM SHAFT OUTER	1	1				
7	8R4-13175-00	SHAFT, WORM	1	1				
8	8R4-13188-00	GEAR, DRIVE (59T)	1	1				
9	137-13148-00	PLATE, CAM THRUST	1	1				
10	90206-11016	WASHER, WAVE	1	1				
11	90201-08624	WASHER, PLATE	1	1				
12	99009-10400	CIRCLIP	1	1				
13	93603-22028	PIN, DOWEL	1	1				
14	93104-29072	OIL SEAL	1	1				
15	98507-06020	SCREW, PAN HEAD	2	2				
16	92907-06100	WASHER, SPRING	2	2				
17	92907-06600	WASHER, PLATE	2	2				
18	91808-22019	PIN, DOWEL	2	2				
19	95827-06030	BOLT, FLANGE	2	2				
20	95827-06025	BOLT, FLANGE	2	2				

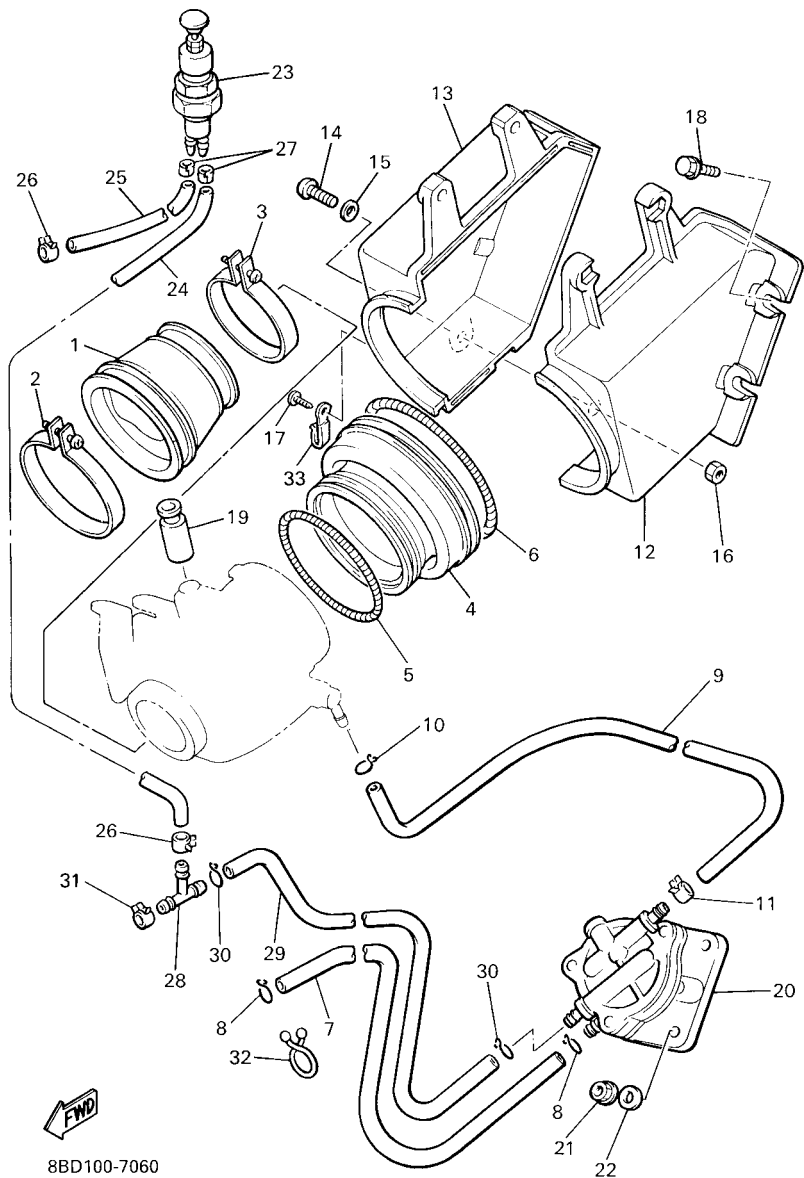

8BD100-7060

FIG. 6 INTAKE

REF. NO.	PART NO.	DESCRIPTION	CAN	JPN	REMARKS
1	8R4-13555-00	MANIFOLD, INTAKE	1	1	
2	90460-64066	CLAMP, HOSE	1	1	
3	90460-51059	CLAMP, HOSE	1	1	
4	8R4-14453-00	JOINT, AIR CLEANER 1	1	1	
5	90506-06261	SPRING, TENSION	1	1	
6	90506-06262	SPRING, TENSION	1	1	
7	90445-115K4	HOSE (L450)	1	1	
8	90467-11032	CLIP	2	2	
9	90445-116G8	HOSE (L135)	1	1	
10	90467-11009	CLIP	1	1	
11	90467-11032	CLIP	1	1	
12	8R4-14431-00	SILENCER, INTAKE 1	1	1	
13	8R4-14441-01	SILENCER, INTAKE 2	1	1	
14	98507-05025	SCREW, PAN HEAD	1	1	
15	92907-05600	WASHER, PLATE	1	1	
16	95707-05300	NUT, FLANGE	1	1	
17	97707-60510	SCREW, TAPPING	1	1	
18	90119-05071	BOLT, WITH WASHER	4	4	
19	8J5-26352-00	BOOT	1	1	
20	8A5-24410-02	FUEL PUMP ASSY	1	1	
21	95707-06500	NUT, FLANGE	2	2	
22	90201-06727	WASHER, PLATE	2	2	
23	8X8-24360-01	PRIMER PUMP ASSY	1		
24	90445-083K9	HOSE (L280)	1		
25	90445-084K0	HOSE (L360)	1		
26	90467-07055	CLIP	2		
27	90468-02025	CLIP	2		

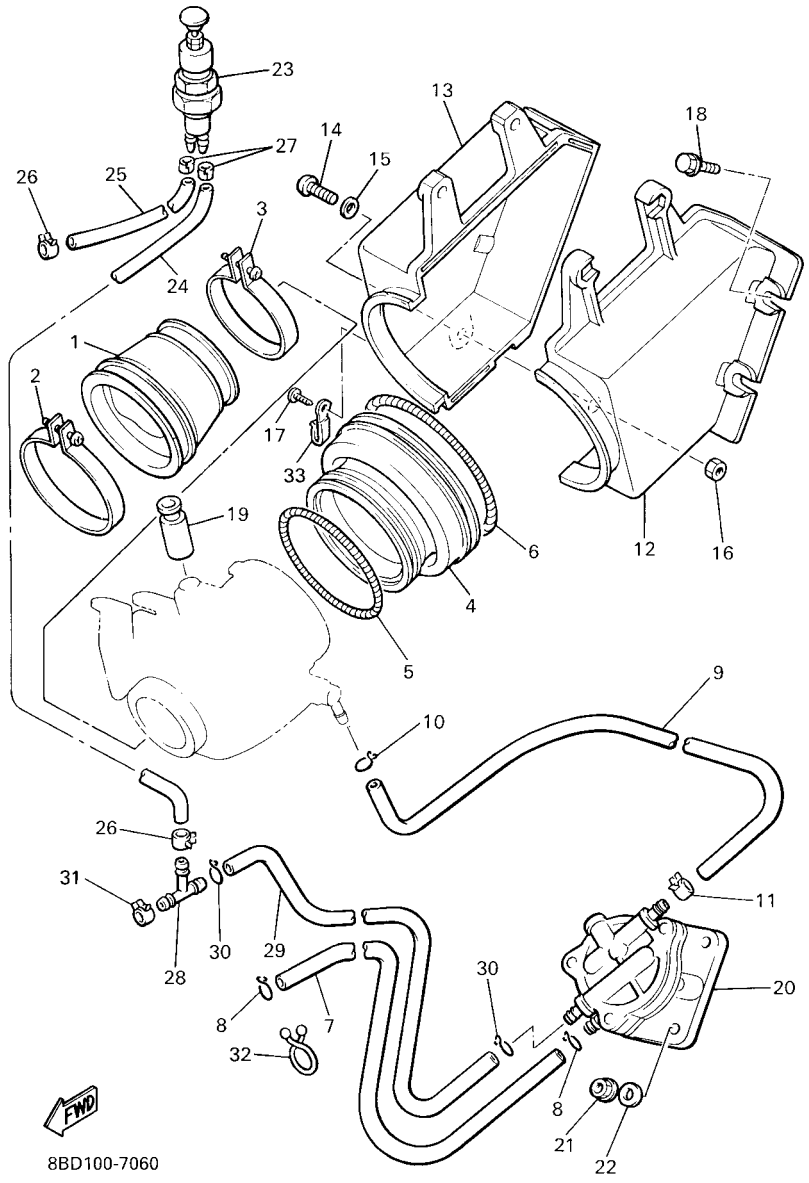

8BD100-7060

FIG. 6 INTAKE

REF. NO.	PART NO.	DESCRIPTION	CAN	JPN	REMARKS
28	815-24379-00	PIPE, JOINT 4	1		
29	90445-114J7	HOSE	1		
30	90467-11009	CLIP	2		
31	90467-11032	CLIP	1	1	
32	90464-16039	CLAMP	1		
33	90465-08333	CLAMP	1	1	

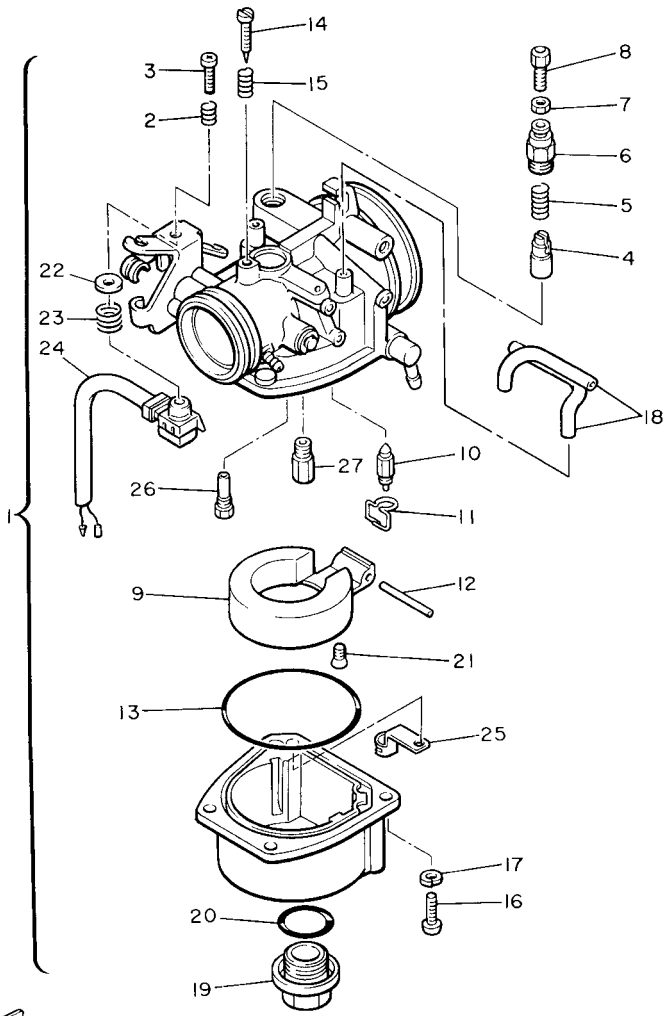

87T100-0070

FIG. 7 CARBURETOR

REF. NO.	PART NO.	DESCRIPTION	CAN	JPN				REMARKS
1	80J-14101-01	CARBURETOR ASSY 1	1					
	80F-14101-01	CARBURETOR ASSY 1		1				
2	80F-14131-00	.SPRING, THROTTLE VALVE	1	1				
3	80F-14121-00	.SCREW, THROTTLE STOP	1	1				
4	371-14993-60	.PLUNGER, STARTER	1	1				
5	90501-08443	.SPRING, COMPRESSION	1	1				
6	8A6-14969-00	.CAP	1	1				
7	8E7-14161-00	.NUT, CABLE ADJUSTING	1	1				
8	8A6-14977-00	.SHAFT, STARTER LEVER	1	1				
9	8G6-14985-01	.FLOAT	1	1				
10	8E7-14546-00	.VALVE, NEEDLE	1	1				
11	663-14159-00	.CLIP	1	1				
12	676-14548-00	.PIN, FLOAT ARM	1	1				
13	8G6-14984-00	.GASKET, FLOAT CHAMBER	1	1				
14	8G6-14521-00	.SCREW, ADJUST	1	1				
15	90501-08214	.SPRING, COMPRESSION	1	1				
16	98502-04040	.SCREW, PAN HEAD	4	4				
17	92902-04100	.WASHER, SPRING	4	4				
18	8R4-14994-00	.PIPE	2	2				
19	8M7-14992-00	.ROD	1	1				
20	93210-19309	.O-RING	1	1				
21	98602-04008	.SCREW, OVAL HEAD	1	1				
22	80F-14146-00	.PLATE	1	1				
23	80F-14133-00	.SPRING, THROTTLE STOP	1	1				
24	87S-8259A-00	.SWITCH, CARBURETOR	1	1				
25	80F-14137-00	.CLIP	1	1				
26	8G6-14948-18	.JET (#78)	1	1				

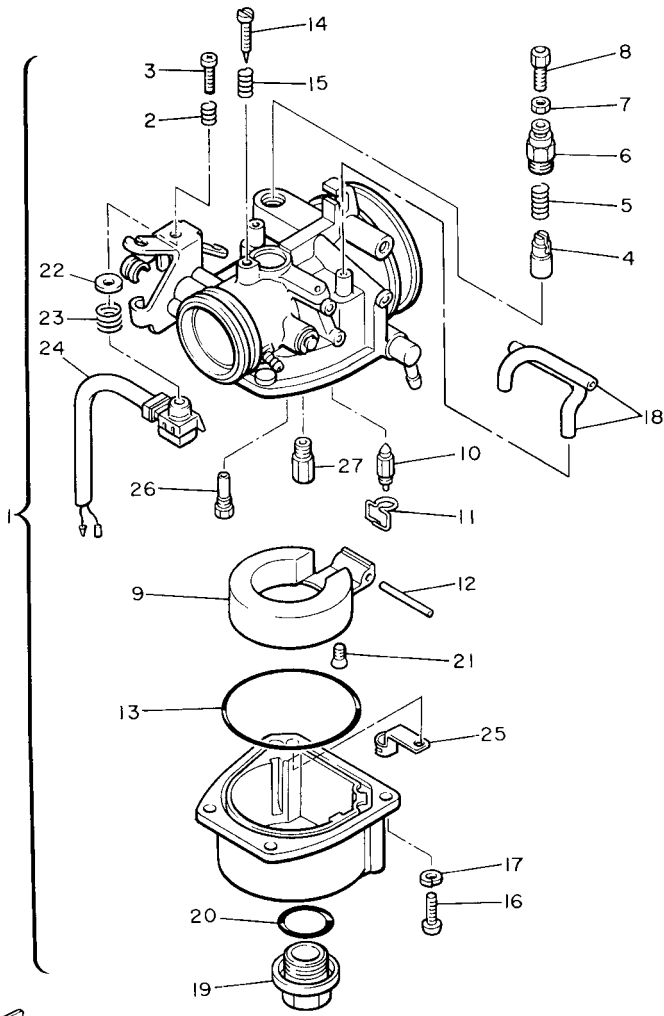

87T100-0070

FIG. 7 CARBURETOR

REF. NO.	PART NO.	DESCRIPTION	CAN	JPN				REMARKS
27	8A6-14516-05	.JET, MAIN (#105)	1	1				STD
	8A6-14515-98	.JET, MAIN (#98)	1	1				AP
	8A6-14516-00	.JET, MAIN (#100)	1	1				AP
	8A6-14516-02	.JET, MAIN (#102)	1	1				AP

FIG. 9 CRANKCASE

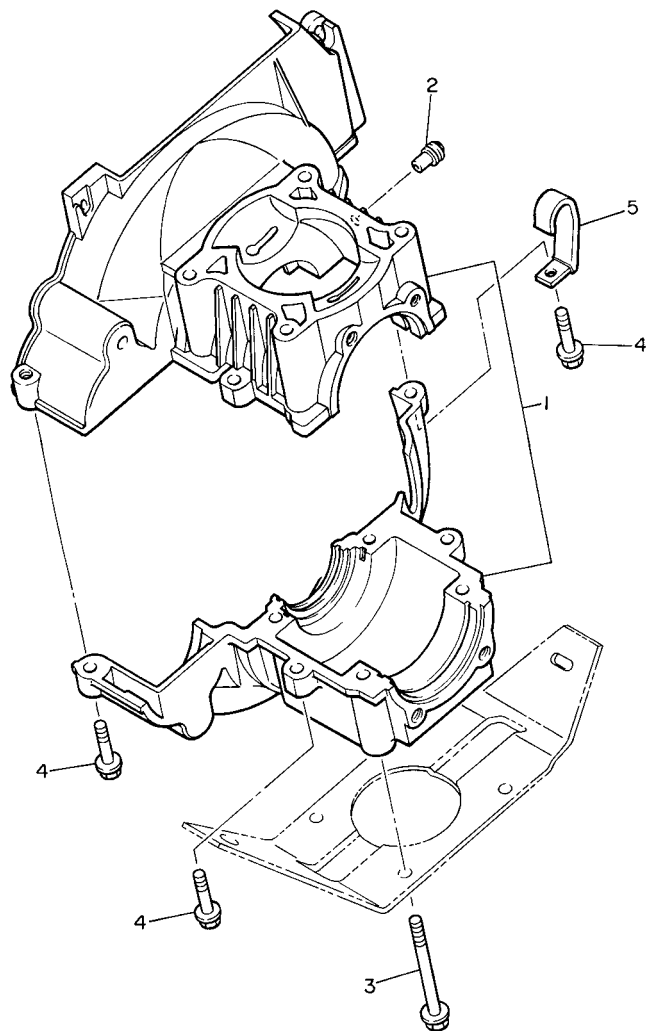

FWD
8R4100-2030

REF. NO.	PART NO.	DESCRIPTION	CAN	JPN				REMARKS
			1	1				
1	8R4-15100-01	CRANKCASE ASSY	1	1				
2	J38-11116-00	JOINT, BREATHER	1	1				
3	95827-08080	BOLT, FLANGE	4	4				
4	95827-08030	BOLT, FLANGE	4	4				
5	90461-06080	CLAMP	1	1				

FIG. 10 STARTER

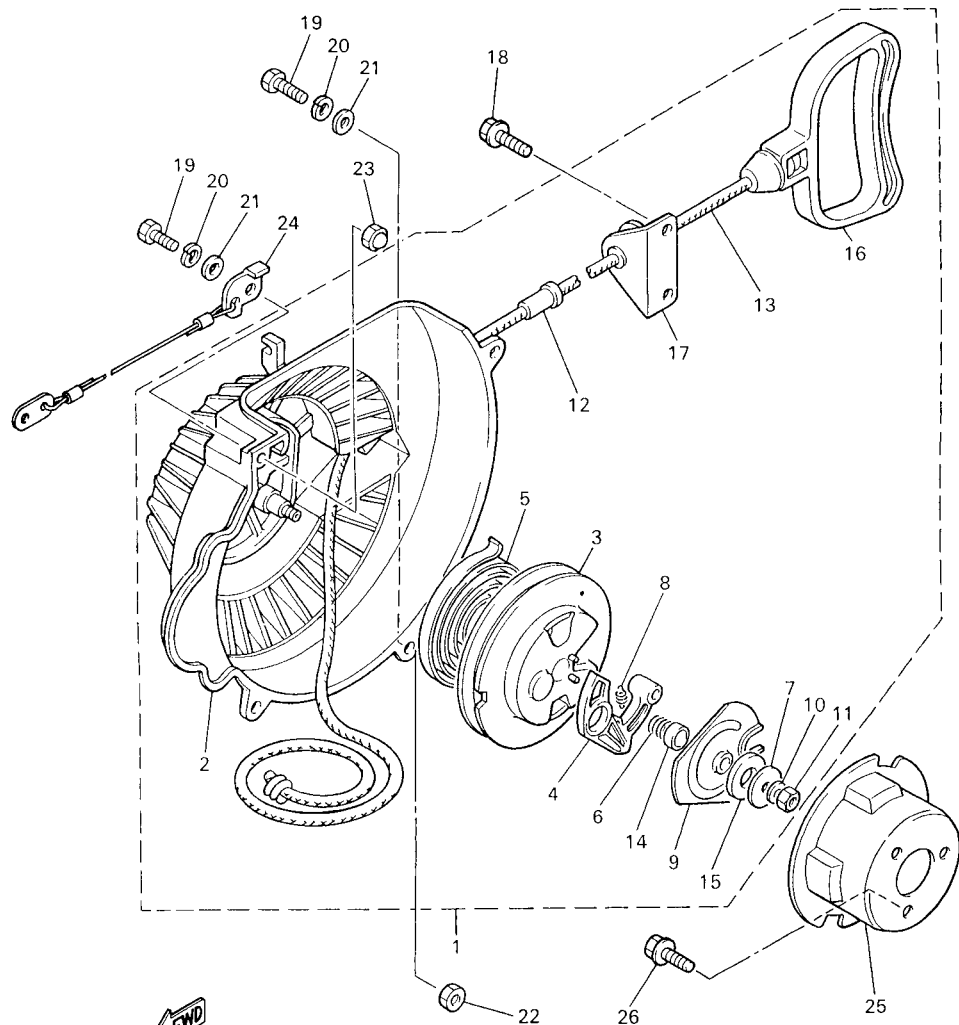

8BD7100-0100

REF. NO.	PART NO.	DESCRIPTION	CAN	JPN	REMARKS
1	8R4-15710-01	STARTER ASSY	1	1	
2	8R4-15711-00	.CASE, STARTER	1	1	
3	8F3-15714-01	.DRUM, SHEAVE	1	1	
4	8F3-15741-01	.PAWL, DRIVE	1	1	
5	8F3-15713-01	.SPRING, STARTER	1	1	
6	8F3-15715-00	.SPRING, FRICTION	1	1	
7	8F3-15739-01	.WASHER, THRUST	1	1	
8	8F3-15734-00	.SPRING, RETURN	1	1	
9	8F3-15716-03	.PLATE, DRIVE	1	1	
10	92901-06100	.WASHER, SPRING	1	1	
11	95301-06700	.NUT	1	1	
12	8F3-15758-00	.GUIDE, ROPE	1	1	
13	8F3-15751-00	.WIRE, STARTER	1	1	
14	8G5-15716-00	.COLLAR	1	1	
15	8G5-15739-00	.WASHER, THRUST	1	1	
16	8R4-15755-00	.HANDLE, STARTER	1	1	
17	8R4-15788-01	.HOLDER, HANDLE	1	1	
18	95807-08016	BOLT, FLANGE	3	3	
19	97007-06025	BOLT	4	4	
20	92907-06100	WASHER, SPRING	4	4	
21	92907-06600	WASHER, PLATE	4	4	
22	95307-06600	NUT	3	3	
23	90176-06038	NUT, CROWN	1	1	
24	8R4-77118-00	STOPPER, SHROUD	1	1	
25	81L-15723-00	PULLEY, STARTER	1	1	
26	95807-08012	BOLT, FLANGE	3	3	

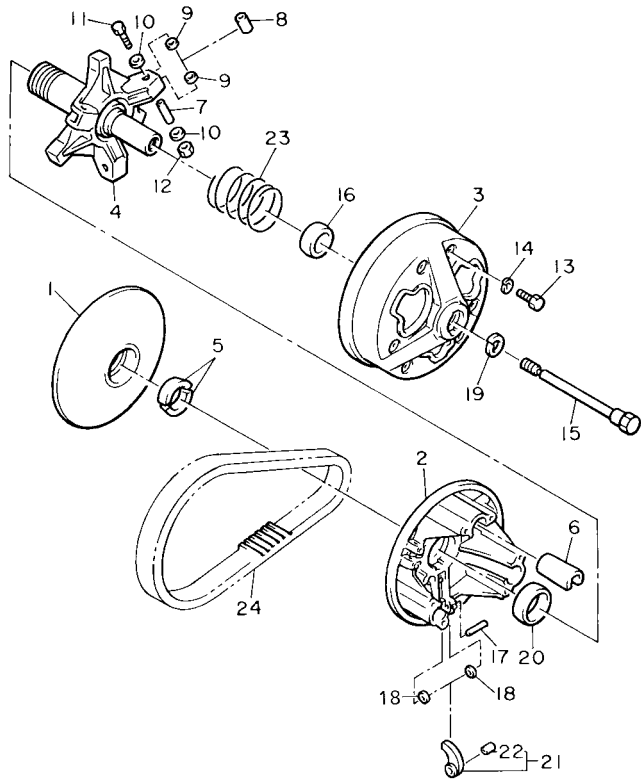



8AF010-3110

FIG. 11 PRIMARY SHEAVE

REF. NO.	PART NO.	DESCRIPTION	CAN	JPN	REMARKS
1	84J-17611-00	SHEAVE, PRIMARY FIXED	1	1	
2	8V0-17621-01	SHEAVE, PRIMARY SLIDING	1	1	
3	8V0-17631-00	CAP	1	1	
4	8V0-17640-02	SPIDER COMPLETE	1	1	
5	8V0-17639-00	STOPPER	2	2	
6	88X-17653-00	SLIDER	3	3	
7	90387-057W5	COLLAR	3	3	
8	90387-087W7	COLLAR	3	3	
9	90202-08205	WASHER, PLATE	6	6	
10	90201-050P9	WASHER, PLATE	6	6	
11	97027-05035	BOLT	3	3	
12	95617-05100	NUT, U	3	3	
13	97017-06030	BOLT	6	6	
14	92907-06600	WASHER, PLATE	6	6	
15	8V0-17647-00	BOLT (L=156.5MM)	1	1	
16	90389-28032	BUSH	1	1	
17	93607-44190	PIN, DOWEL	3	3	
18	90201-077F5	WASHER, PLATE	6	6	
19	92907-16100	WASHER	1	1	
20	90389-40029	BUSH	1	1	
21	8V8-W176A-00	WEIGHT, WITH BUSH	3	3	
22	90386-07152	.BUSH	1	1	
23	90501-554E8	SPRING, COMPRESSION	1	1	
24	89X-17641-00	V-BELT	1	1	

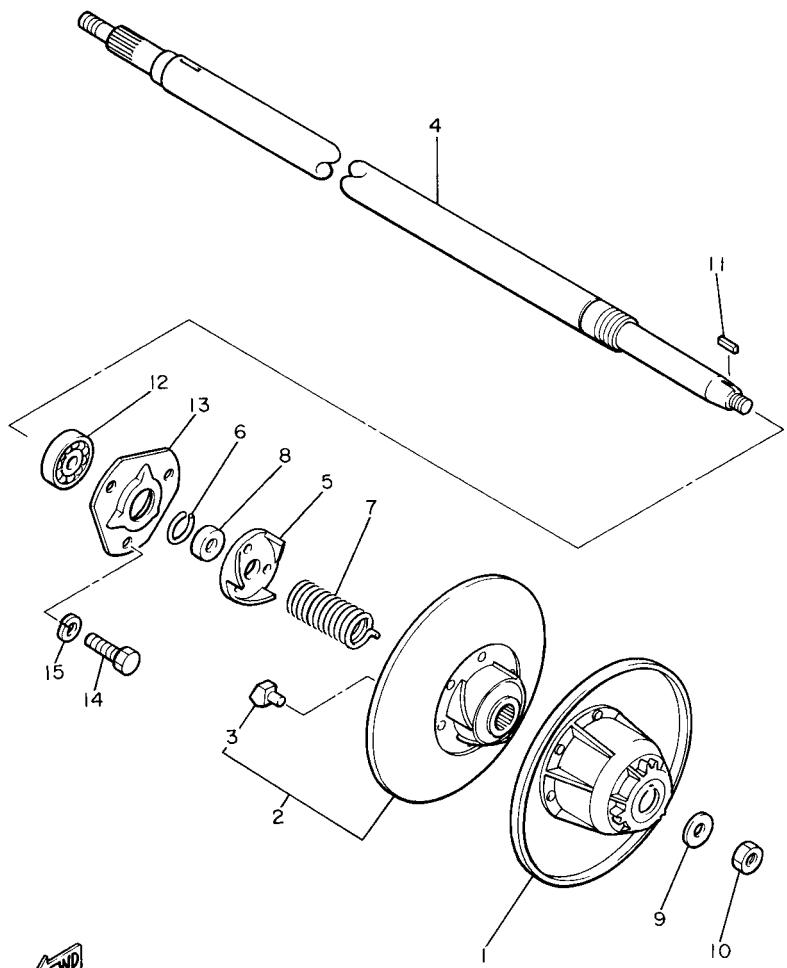
FIG. 12 SECONDARY SHEAVE



8R4100-2130

REF. NO.	PART NO.	DESCRIPTION	CAN	JPN	REMARKS
1	8R4-17660-00	SECONDARY FIXED SHEAVE COMP.	1	1	
2	8R4-17670-01	SECONDARY SLIDING SHEAVE	1	1	
3	8R4-17688-00	.SHOE, RAMP	3	3	
4	8R4-17681-01	SHAFT, SECONDARY	1	1	
5	8R4-17684-00	SEAT, SECONDARY SPRING	1	1	
6	93440-25100	CIRCLIP	1	1	
7	90508-40080	SPRING, TORSION	1	1	
8	90387-260W3	COLLAR	1	1	
9	90201-122H1	WASHER, PLATE	1	1	
10	90185-12061	NUT, SELF-LOCKING	1	1	
11	90282-05047	KEY, STRAIGHT	1	1	
12	93306-20582	BEARING (62052RSC3)	1	1	
13	8R4-47631-00	HOUSING, BEARING	1	1	
14	97027-08016	BOLT	3	3	
15	92907-08600	WASHER, PLATE	3	3	

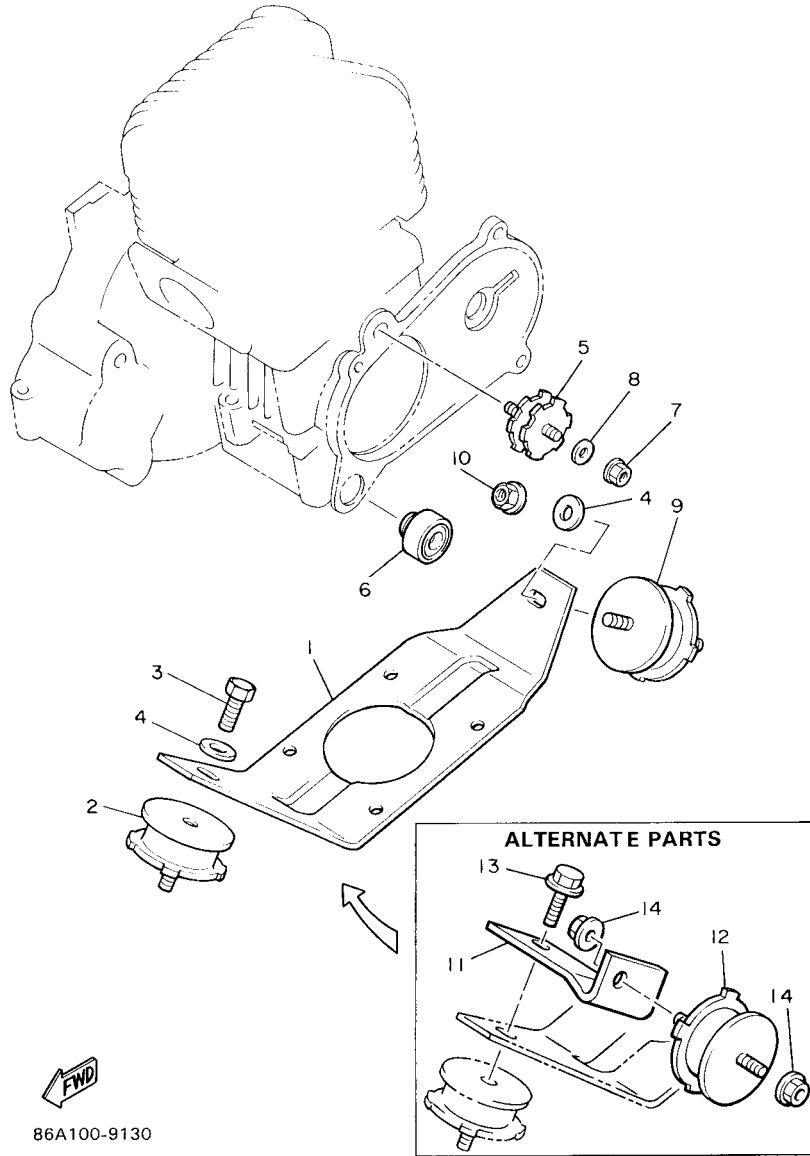

86A100-9130

FIG. 13 ENGINE BRACKET

REF. NO.	PART NO.	DESCRIPTION	CAN	JPN	REMARKS
1	8R4-21411-00	BRACKET, ENGINE 1	1	1	
2	8R4-21485-00	DAMPER, RUBBER 1	1	1	
3	95807-10014	BOLT, FLANGE	1	1	
4	90201-10321	WASHER, PLATE	2	2	
5	8V7-21486-00	DAMPER 2	1	1	
6	8R4-21488-01	DAMPER	1	1	
7	95707-08500	NUT, FLANGE	1	1	
8	92907-08200	WASHER	1	1	
9	8F3-21486-00	DAMPER 2	1	1	
10	90179-10279	NUT	1	1	
11	86A-21419-00	BRACKET, ENGINE 2	1	1	AP
12	8F3-21486-00	DAMPER 2	1	1	AP
13	95807-10020	BOLT, FLANGE	1	1	AP
14	95707-10500	NUT, FLANGE	2	2	AP

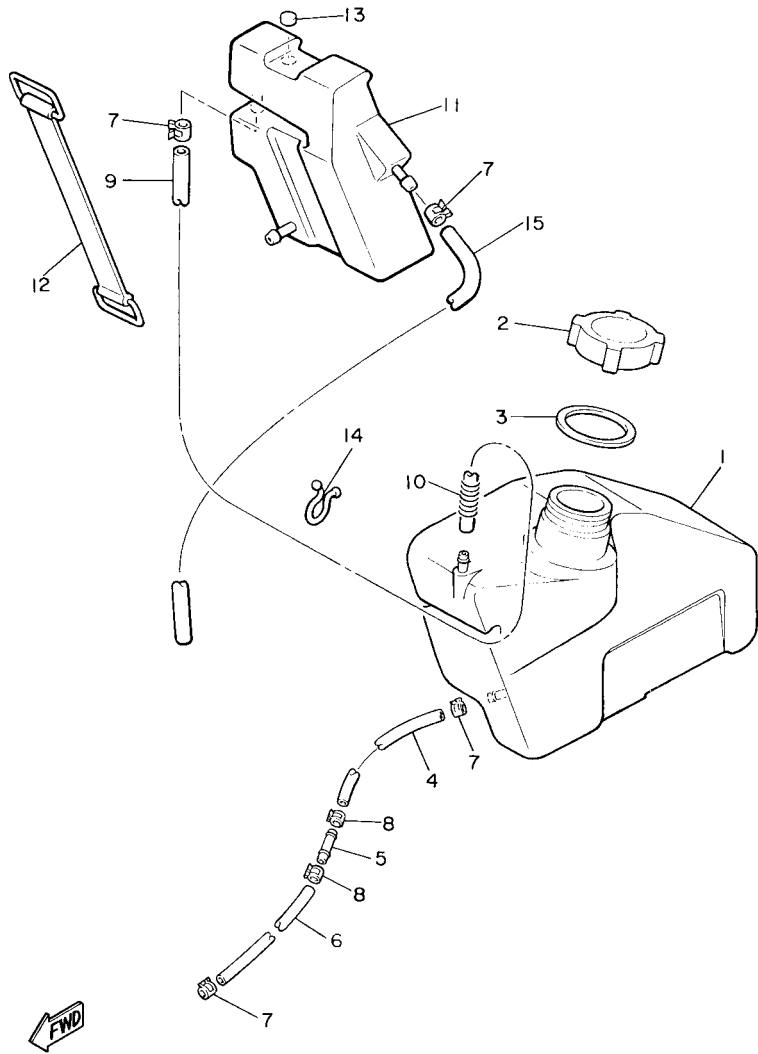

8AE100-3140

FIG. 14 OIL TANK

REF. NO.	PART NO.	DESCRIPTION	CAN	JPN				REMARKS
1	8R4-21751-00	TANK, OIL	1	1				
2	863-21771-00	BODY, CAP	1	1				
3	90430-31003	GASKET	1	1				
4	91A30-05045	TUBE, FLEXIBLE VINYL	1	1				
5	8H8-24376-00	PIPE, JOINT 1	1	1				
6	91A30-05024	TUBE, FLEXIBLE VINYL	1	1				
7	90467-09026	CLIP	2	2				
8	90467-08017	CLIP	2	2				
9	91A30-05065	TUBE, FLEXIBLE VINYL	1	1				
10	90501-083J8	SPRING, COMPRESSION	1	1				
11	8V7-21871-00	TANK, RECOVERY	1	1				
12	8V7-21776-00	BAND, TANK FITTING	1	1				
13	90338-10132	PLUG	1	1				
14	90464-16039	CLAMP	4	5				
15	91A20-05045	TUBE, FLEXIBLE VINYL	1	1				

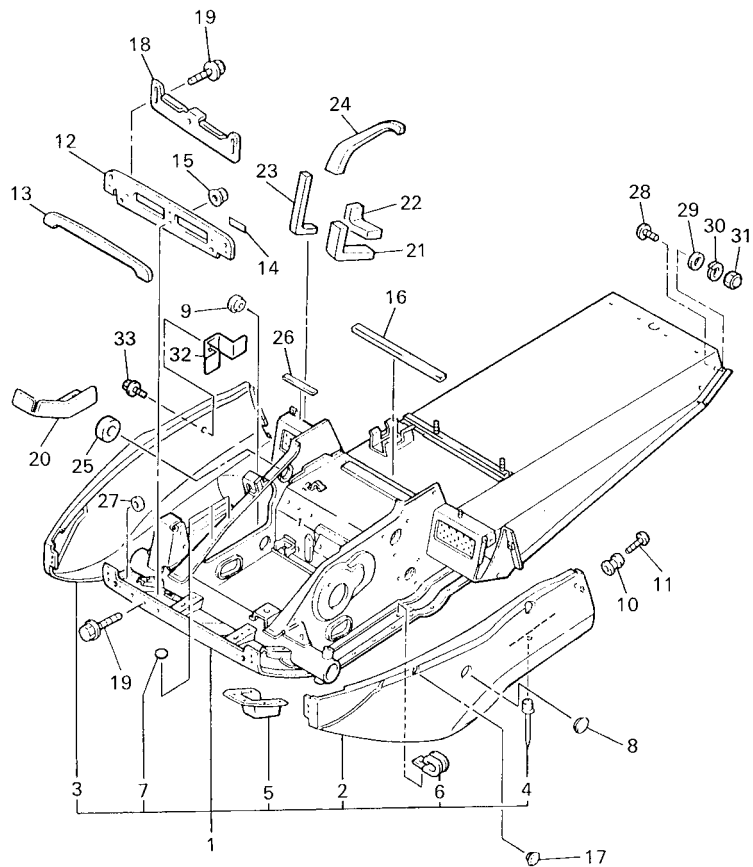

8BD100-6150

FIG. 15 FRAME

REF. NO.	PART NO.	DESCRIPTION	CAN	JPN				REMARKS
1	8BD-21910-00	FRAME COMP.	1	1				
2	84A-21982-00	.HOOD 1	1	1				
3	84A-21983-00	.HOOD 2	1	1				
4	90267-48060	.RIVET, BLIND	58	58				
5	80F-2198G-00	.COVER 2	1	1				
6	90465-08028	.CLAMP	3	3				
7	80F-21998-00	.SPACER	5	5				
8	90338-40099	PLUG	2	2				
9	90480-40047	GROMMET	1	1				
10	8M6-77175-00	HOLDER, LATCH	2	2				
11	98907-06030	SCREW, BIND	2	2				
12	8V7-2198F-00	COVER 1	1	1				
13	8V7-77198-01	DAMPER 1	1	1				
14	8BE-77762-00	LABEL, WARNING 2	1					
	8Y0-77762-90	LABEL, WARNING 2		1				
15	95707-06500	NUT, FLANGE	1	1				
16	8R4-23891-00	SHIELD, NOISE 1	1	1				
17	90338-09127	PLUG	2	2				
18	8V7-2198G-00	COVER 2	1	1				
19	95807-06012	BOLT, FLANGE	8	8				
20	80F-2199H-00	SHIELD, HEAT	1	1				
21	8V7-21961-00	PATCH 1	1	1				
22	8V7-21962-00	PATCH 2	1	1				
23	8V7-21963-00	PATCH 3	1	1				
24	82X-21964-00	PATCH 4	1	1				
25	80F-21967-00	PATCH 7	1	1				
26	80F-21988-00	PATCH 8	1	1				

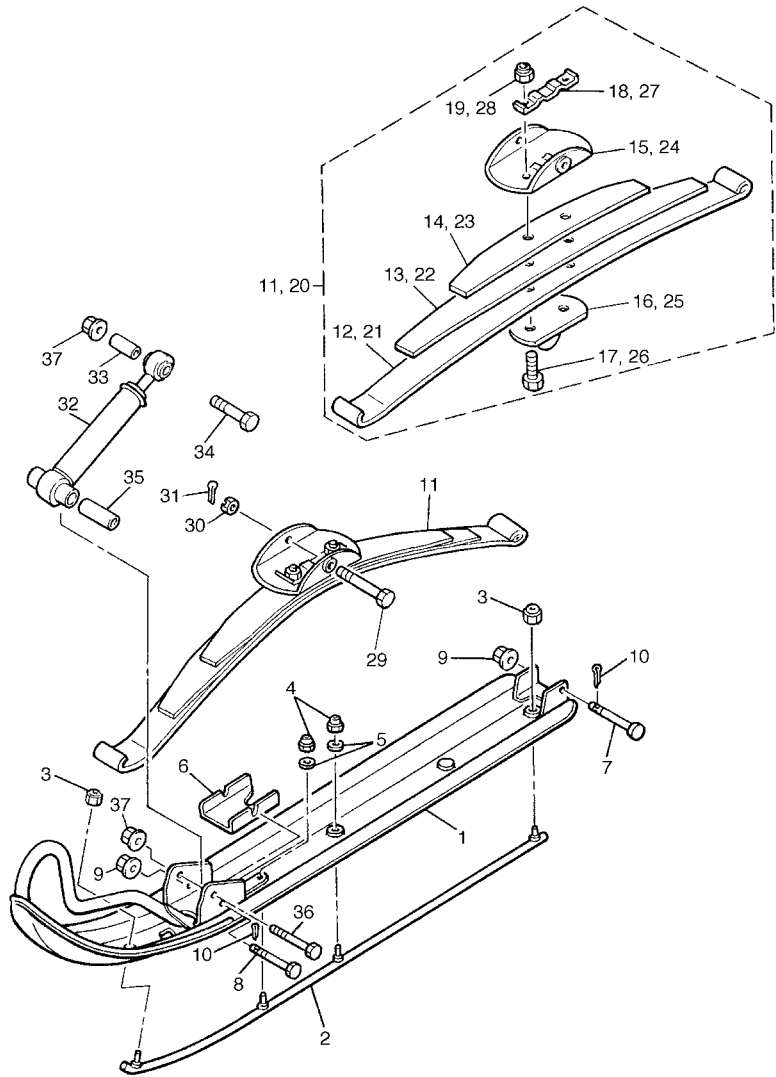

8BDC100-D160

FIG. 16 SKI

REF. NO.	PART NO.	DESCRIPTION	CAN	JPN	REMARKS
1	86C-23710-00	SKI COMP. 1	2	2	
2	8E3-23731-01	RUNNER 1	2	2	
3	95607-08200	NUT, SELF-LOCKING	4	4	
4	90185-08055	NUT, SELF-LOCKING	4	4	
5	92907-08600	WASHER, PLATE	4	4	
6	888-23735-00	PLATE, WEAR 1	2	2	
7	90102-08028	BOLT, WITH HOLE	2	2	
8	90102-08027	BOLT, WITH HOLE	2	2	
9	95707-08300	NUT, NYLON	4	4	
10	91401-20015	PIN, COTTER	4	4	
11	8R4-23760-10	SPRING ASSY 1	1	1	
12	8F3-23761-10	.LEAF 1	1	1	
13	8F3-23762-10	.LEAF 2	1	1	
14	8F3-23763-10	.LEAF 3	1	1	
15	8G6-23766-00	.SADDLE 1	1	1	
16	878-23768-00	.SEAT, SPRING 1	1	1	
17	90109-105E7	.BOLT	2	2	
18	90215-10155	.WASHER, LOCK	1	1	
19	90185-10085	.NUT, SELF-LOCKING	2	2	
20	8R4-23770-10	SPRING ASSY 2	1	1	
21	8F3-23761-10	.LEAF 1	1	1	
22	8F3-23762-10	.LEAF 2	1	1	
23	8F3-23763-10	.LEAF 3	1	1	
24	8G6-23766-00	.SADDLE 1	1	1	
25	878-23768-00	.SEAT, SPRING 1	1	1	
26	90109-105E7	.BOLT	2	2	
27	90215-10155	.WASHER, LOCK	1	1	

FIG. 17 STEERING

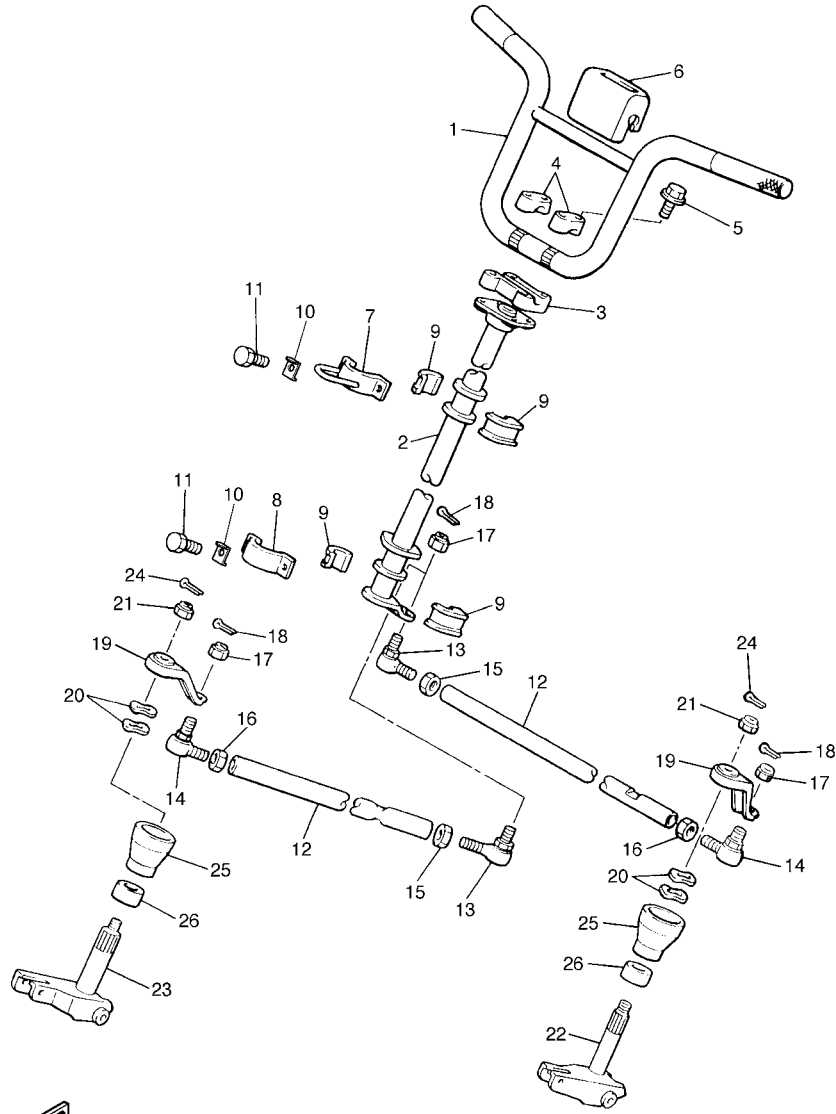

8BDC100-D170

REF. NO.	PART NO.	DESCRIPTION	CAN	JPN	REMARKS
1	86A-23811-90	COLUMN, STEERING	1	1	
2	8R4-23813-00	COLUMN, STEERING 2	1	1	
3	8G5-23814-00	HOLDER, HANDLE UNDER	1	1	
4	8K1-23814-00	HOLDER, HANDLE	2	2	
5	95827-08055	BOLT, FLANGE	4	4	
6	8F3-23818-00	COVER, STEERING	1	1	
7	8Y4-23872-00	HOLDER, BEARING	1	1	
8	84M-23868-00	BRACKET, STEERING LOWER	1	1	
9	8F3-23812-00	PLANE BEARING, STEERING	4	4	
10	8AC-23894-00	WASHER, LOCK 1	4	4	
11	90101-08005	BOLT	4	4	
12	8R4-23821-00	ROD, STEERING RELAY	2	2	
13	86X-23841-00	JOINT, UNIVERSAL 1	2	2	
14	86X-23845-00	JOINT, UNIVERSAL 2	2	2	
15	95307-10700	NUT	2	2	
16	90170-10186	NUT	2	2	(L.H. THREAD)
17	90185-10085	NUT, SELF-LOCKING	4	4	
18	91401-25020	PIN, COTTER	4	4	
19	88P-23851-00	ARM, OUTSIDE 1	2	2	
20	90206-20037	WASHER, WAVE	4	4	
21	95707-10300	NUT, FLANGE	2	2	
22	8Y1-23853-00	COLUMN, SKI 1	1	1	
23	8Y1-23854-00	COLUMN, SKI 2	1	1	
24	91401-25020	PIN, COTTER	2	2	
25	8U0-2198G-00	COVER 2	2	2	
26	8Y1-21998-00	SPACER	2	2	

FIG. 18 STEERING GATE

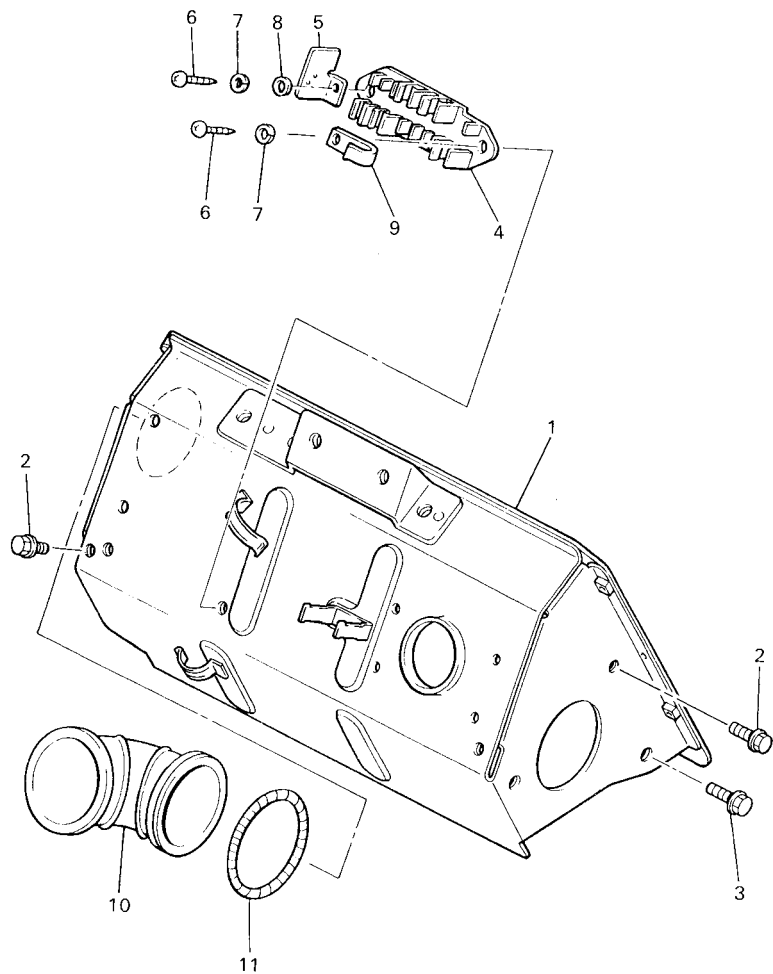

8BD100-5180

REF. NO.	PART NO.	DESCRIPTION	CAN	JPN	REMARKS
1	8BD-23871-00	GATE, STEERING	1	1	
2	95827-06012	BOLT, FLANGE	4	4	
3	90105-08688	BOLT, FLANGE	2	2	
4	8F3-21794-00	HOLDER, COUPLER	1	1	
5	8AE-23892-00	SHIELD, HEAT	1	1	
6	98507-06016	SCREW, PAN HEAD	2	2	
7	92907-06600	WASHER, PLATE	2	2	
8	92907-06200	WASHER	1	1	
9	90465-08028	CLAMP	1	1	
10	8A5-14423-00	PIPE, SUCTION 1	1	1	
11	90506-06083	SPRING, TENSION	1	1	

FIG. 19 FUEL TANK

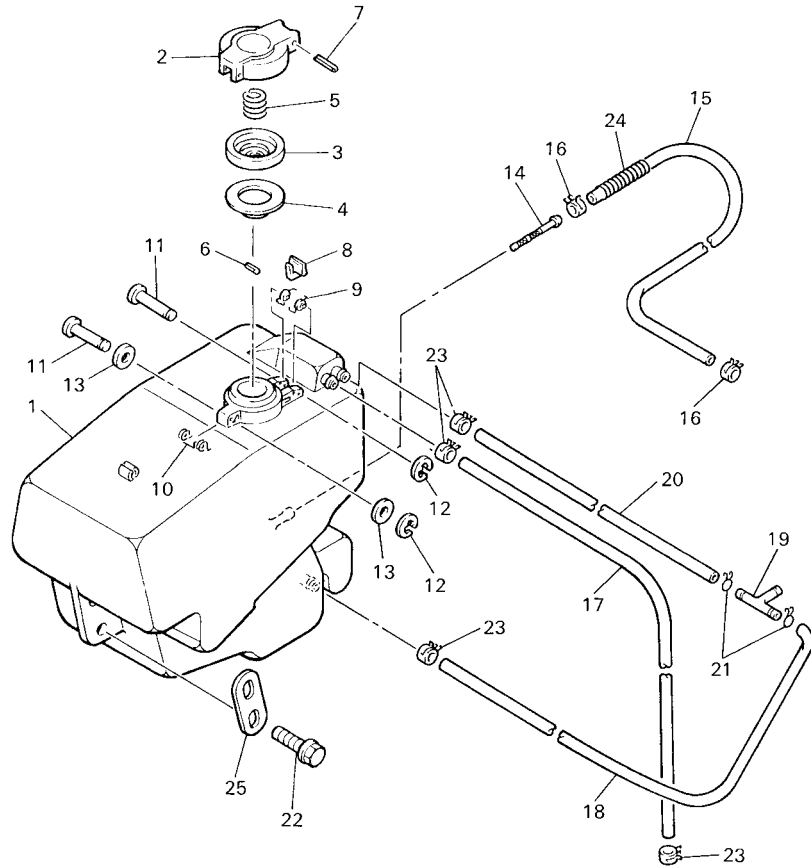

8BD100-5190

REF. NO.	PART NO.	DESCRIPTION	CAN	JPN				REMARKS
1	8R4-24111-02	TANK, FUEL	1	1				
2	8A5-24611-00	BODY, CAP	1	1				
3	813-24613-01	DISC, CAP	1	1				
4	89A-24641-00	GASKET, CAP 1	1	1				
5	90501-20130	SPRING, COMPRESSION	1	1				
6	91609-30016	PIN, SPRING	1	1				
7	91609-25032	PIN, SPRING	1	1				
8	83M-24628-00	HOOK	1	1				
9	90508-10715	SPRING, TORSION	1	1				
10	90508-08353	SPRING, TORSION	1	1				
11	90249-03017	PIN	2	2				
12	93430-02001	CIRCLIP	2	2				
13	90201-03313	WASHER, PLATE	2	2				
14	22F-24514-01	NET, FILTER 1	1	1				
15	90445-113K5	HOSE (L520)	1	1				
16	90467-11028	CLIP	2	2				
17	91A20-05140	TUBE, FLEXIBLE VINYL	1	1				
18	91A20-05090	TUBE, FLEXIBLE VINYL	1	1				
19	801-24376-00	PIPE, JOINT 1	1	1				
20	90445-097J9	HOSE (L520)	1	1				
21	90467-08017	CLIP	2	2				
22	90105-08688	BOLT, FLANGE	4	4				
23	90467-09026	CLIP	6	6				
24	8F3-24327-00	PROTECTOR, PIPE	1	1				
25	8R4-24186-00	WASHER, SPECIAL	2	2				

FIG. 20 FUEL TANK 2

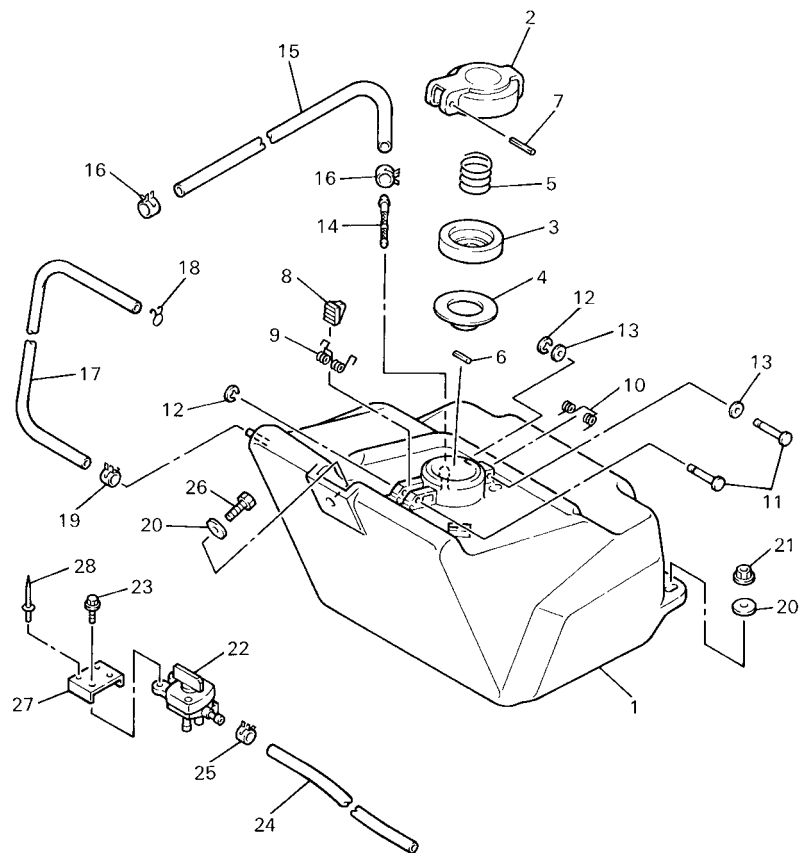

8BD5100-8200

REF. NO.	PART NO.	DESCRIPTION	CAN	JPN				REMARKS
1	8BD-24211-00	TANK, FUEL	1	1				
2	8A5-24611-00	BODY, CAP	1	1				
3	813-24613-01	DISC, CAP	1	1				
4	89A-24641-00	GASKET, CAP 1	1	1				
5	90501-20130	SPRING, COMPRESSION	1	1				
6	91609-30016	PIN, SPRING	1	1				
7	91609-25032	PIN, SPRING	1	1				
8	83M-24628-00	HOOK	1	1				
9	90508-10715	SPRING, TORSION	1	1				
10	90508-08353	SPRING, TORSION	1	1				
11	90249-03017	PIN	2	2				
12	93430-02001	CIRCLIP	2	2				
13	90201-03313	WASHER, PLATE	2	2				
14	22F-24514-01	NET, FILTER 1	1	1				
15	90445-113K6	HOSE (L650)	1	1				
16	90467-11028	CLIP	2	2				
17	90445-095K5	HOSE (L960)	1	1				
18	90467-08017	CLIP	1	1				
19	90467-09026	CLIP	1	1				
20	90201-08784	WASHER, PLATE	3	3				
21	95707-08300	NUT, NYLON	2	2				
22	8BD-24500-00	FUEL COCK ASSY 1	1	1				
23	95807-06008	BOLT, FLANGE	2	2				
24	90445-111H4	HOSE (L95)	1					
	90445-114J9	HOSE (L265)		1				
25	90467-11028	CLIP	1	1				
26	97027-08020	BOLT	1	1				

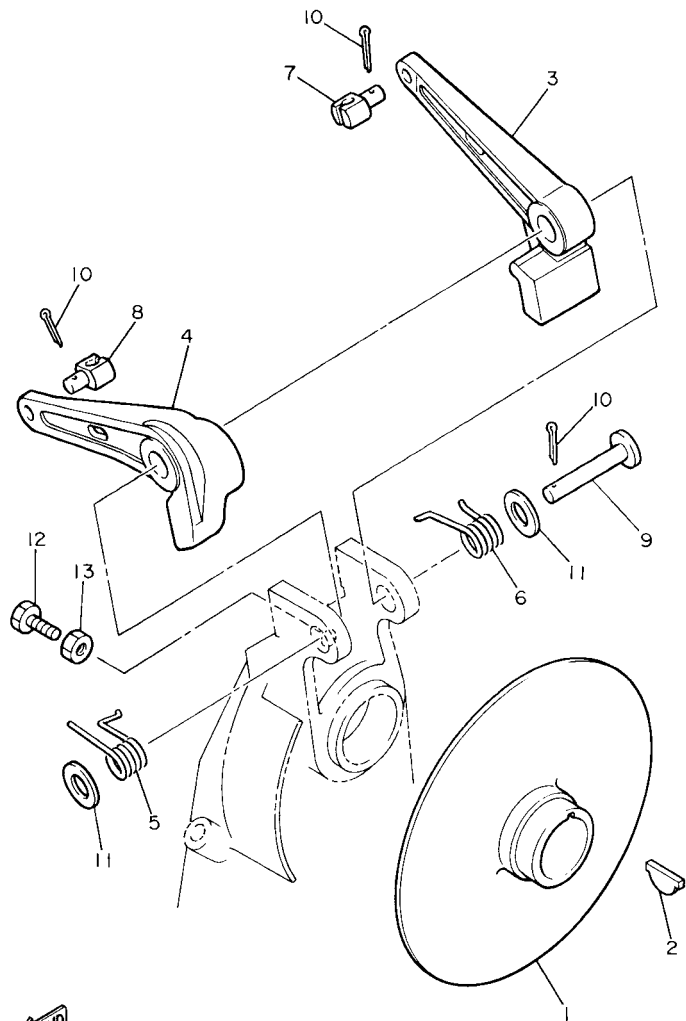

8R4100-2140

FIG. 22 BRAKE

REF. NO.	PART NO.	DESCRIPTION	CAN	JPN				REMARKS
1	8R4-25711-00	DISC, BRAKE	1	1				
2	8J7-25848-00	KEY	1	1				
3	8BC-25730-00	CALIPER BODY COMP.1	1	1				
4	8BC-25740-00	CALIPER BODY COMP. 2	1	1				
5	90508-29601	SPRING, TORSION	1	1				
6	90508-29602	SPRING, TORSION	1	1				
7	90249-06012	PIN	1	1				
8	90249-06009	PIN	1	1				
9	90240-08068	PIN, CLEVIS	1	1				
10	91401-20015	PIN, COTTER	3	3				
11	92907-08600	WASHER, PLATE	2	2				
12	90101-06534	BOLT	1	1				
13	95307-06700	NUT	1	1				

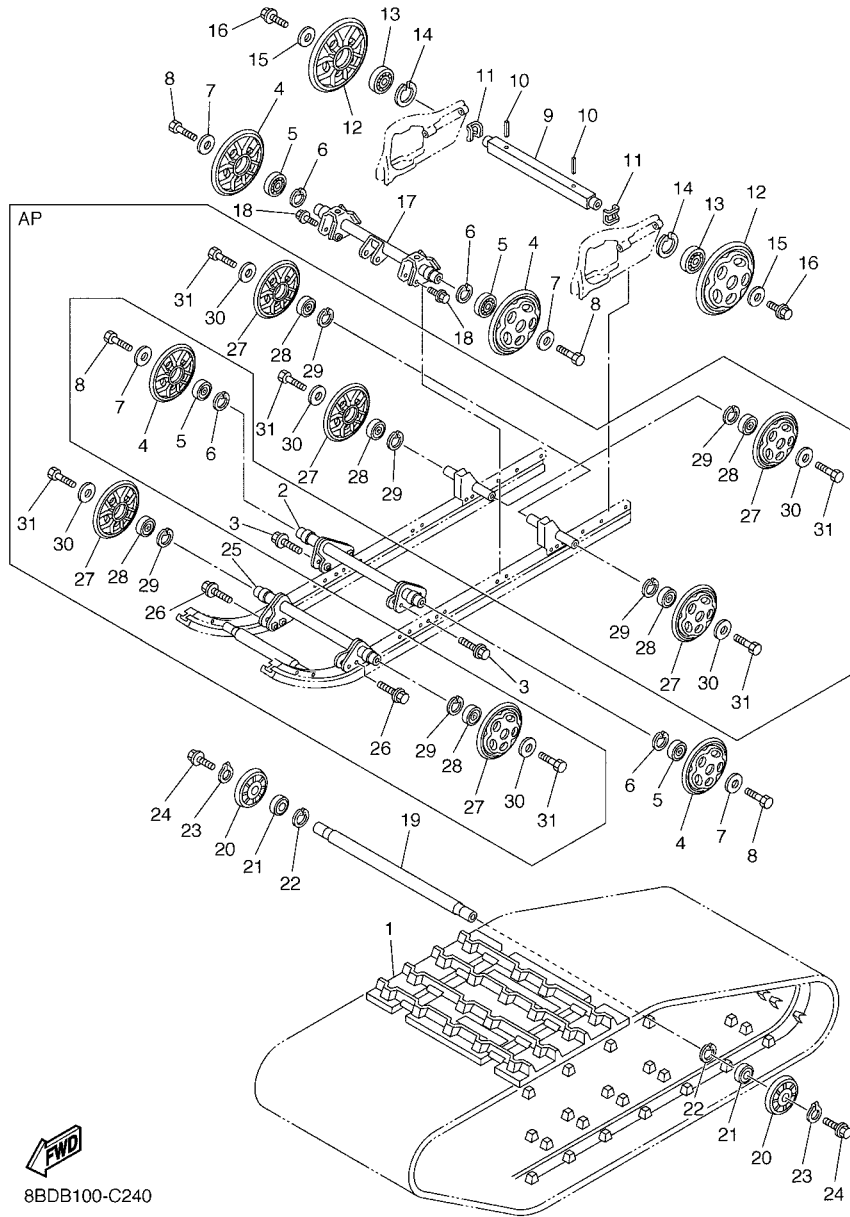

8BDB100-C240

FIG. 24 TRACK SUSPENSION 1

REF. NO.	PART NO.	DESCRIPTION	CAN	JPN	REMARKS
1	8BD-47110-00	TRACK ASSY	1	1	
2	8T9-47451-00	BAR, SUSPENSION	1	1	
3	90101-06348	BOLT	6	6	
4	87M-47320-00	SUSPENSION WHEEL COMP.	4	4	
5	93306-00444	BEARING	4	4	
6	99009-42500	CIRCLIP	4	4	
7	90201-08681	WASHER, PLATE	4	4	
8	90109-08559	BOLT	4	4	
9	8E3-47521-00	AXLE, REAR	1	1	
10	91609-40040	PIN, SPRING	2	2	
11	8E3-47384-00	WASHER	2	2	
12	8L4-47530-00	GUIDE WHEEL COMP.	2	2	
13	93306-20469	BEARING	2	2	
14	99009-47500	CIRCLIP	2	2	
15	90201-083A8	WASHER, PLATE	2	2	
16	95827-08020	BOLT, FLANGE	2	2	
17	8V5-47451-00	BAR, SUSPENSION	1	1	
18	90119-08008	BOLT, WITH WASHER	4	4	
19	8L1-47461-00	IDLER	1	1	
20	8H8-47320-00	SUSPENSION WHEEL COMP.	2	2	
21	93306-00444	BEARING	2	2	
22	99009-42500	CIRCLIP	2	2	
23	99009-20400	CIRCLIP	2	2	
24	95827-08020	BOLT, FLANGE	2	2	
25	8T9-47451-00	BAR, SUSPENSION	1	1	
26	90101-06348	BOLT	6	6	
27	87M-47320-00	SUSPENSION WHEEL COMP.	6	6	

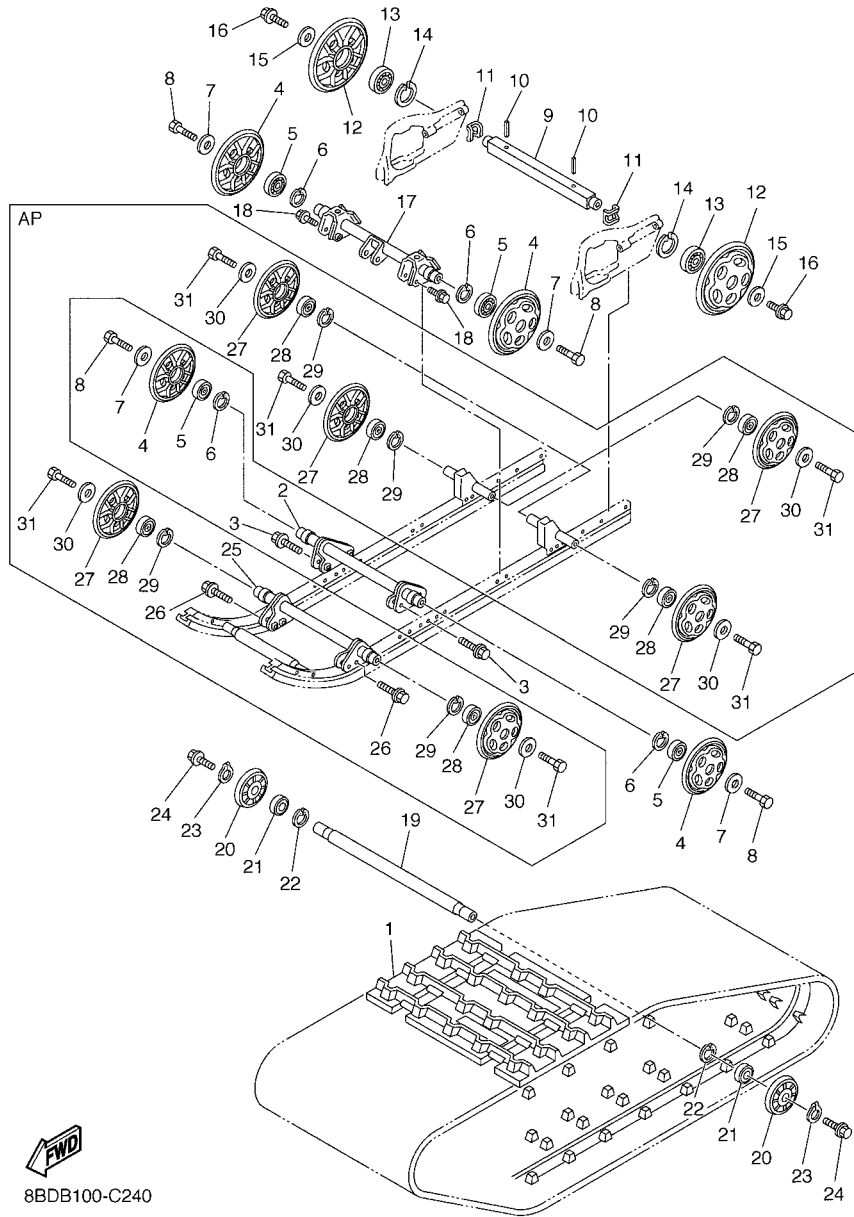
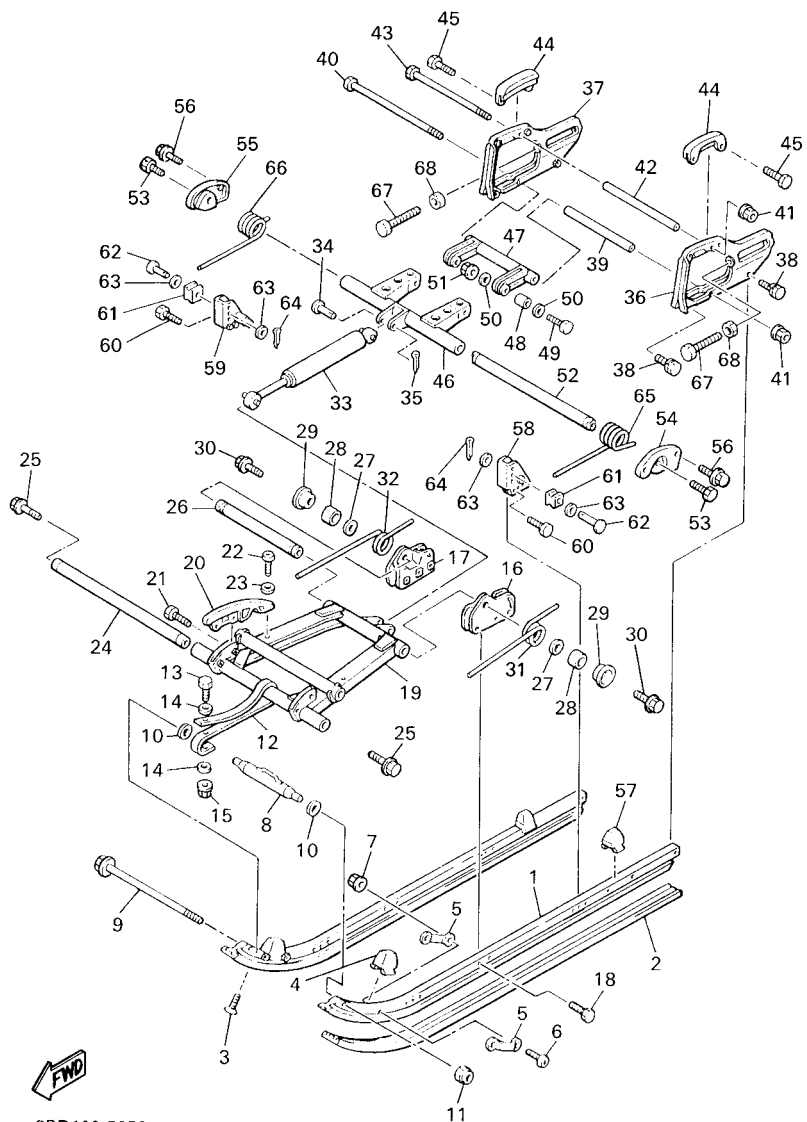

FIG. 24 TRACK SUSPENSION 1

REF. NO.	PART NO.	DESCRIPTION	CAN	JPN				REMARKS
28	93306-00444	BEARING	6	6				
29	99009-42500	CIRCLIP	6	6				
30	90201-08681	WASHER, PLATE	6	6				
31	90109-08559	BOLT	6	6				

FIG. 25 TRACK SUSPENSION 2



8BD100-5250

REF. NO.	PART NO.	DESCRIPTION	CAN	JPN	REMARKS
1	80E-47411-00	FRAME, SLIDING 1	2	2	
2	8X0-47421-00	RUNNER, SLIDING 1	2	2	
3	90151-06010	SCREW, COUNTERSUNK	2	2	
4	888-47456-01	DAMPER 1	2	2	
5	885-47458-01	PLATE, DAMPER	4	4	
6	97007-05035	BOLT	4	4	
7	95707-05300	NUT, FLANGE	4	4	
8	899-47415-00	BRACKET 1	1	1	
9	95827-08260	BOLT, FLANGE	1	1	
10	90201-08093	WASHER, PLATE	2	2	
11	95607-08200	NUT, SELF-LOCKING	1	1	
12	888-47495-02	STOPPER 1	1	1	
13	97007-06035	BOLT	1	1	
14	90201-06747	WASHER, PLATE	2	2	
15	95707-06300	NUT, FLANGE	1	1	
16	85A-47416-00	BRACKET 2	1	1	
17	85A-47419-00	BRACKET 7	1	1	
18	90101-06348	BOLT	6	6	
19	89D-47331-00	ARM, PIVOT 1	1	1	
20	8G8-47422-00	RUNNER, SLIDING 2	2	2	
21	97007-06020	BOLT	4	4	
22	98507-06020	SCREW, PAN HEAD	2	2	
23	92907-06600	WASHER, PLATE	2	2	
24	8A5-47465-02	SHAFT 1	1	1	
25	90109-10771	BOLT	2	2	
26	8A5-47485-02	SHAFT 3	1	1	
27	90201-10149	WASHER, PLATE	2	2	

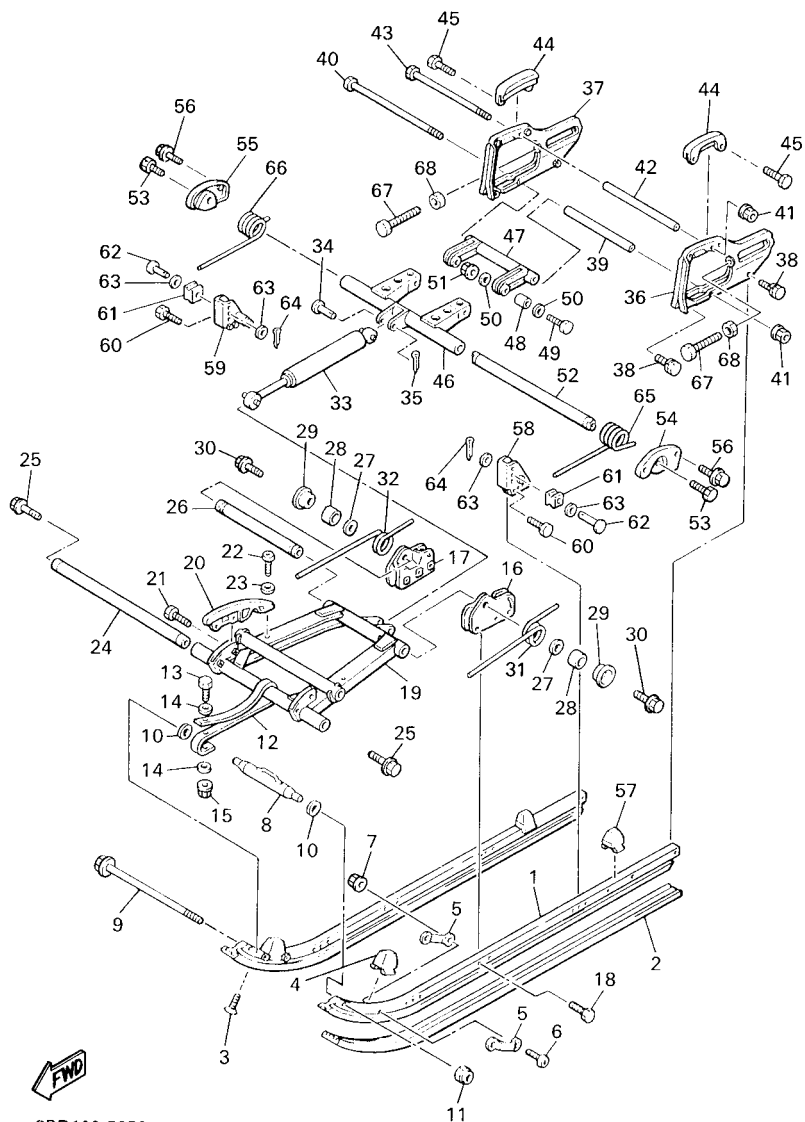

8BD100-5250

FIG. 25 TRACK SUSPENSION 2

REF. NO.	PART NO.	DESCRIPTION	CAN	JPN	REMARKS
28	90387-106L3	COLLAR	2	2	
29	90387-206L2	COLLAR	2	2	
30	95827-10080	BOLT, FLANGE	2	2	
31	80E-47471-01	SPRING, FRONT 1	1	1	
32	80E-47472-01	SPRING, FRONT 2	1	1	
33	8E7-47480-00	SHOCK ABSORBER	1	1	
34	90240-12115	PIN, CLEVIS	2	2	
35	91401-30020	PIN, COTTER	2	2	
36	8E3-47412-00	FRAME, SLIDING 2	1	1	
37	8E3-47413-00	FRAME, SLIDING 3	1	1	
38	90119-08008	BOLT, WITH WASHER	4	4	
39	90387-08496	COLLAR	1	1	
40	90101-08374	BOLT	1	1	
41	95707-08300	NUT, NYLON	2	2	
42	90387-08497	COLLAR	1	1	
43	97027-08250	BOLT	1	1	
44	8E3-47422-00	RUNNER, SLIDING 2	2	2	
45	90119-06097	BOLT, WITH WASHER	4	4	
46	8A5-47332-00	ARM, PIVOT 2	1	1	
47	8A5-47417-00	BRACKET 3	1	1	
48	90387-08508	COLLAR	2	2	
49	97027-08045	BOLT	2	2	
50	90201-08093	WASHER, PLATE	4	4	
51	95707-08300	NUT, NYLON	2	2	
52	8A5-47475-02	SHAFT 2	1	1	
53	90109-10771	BOLT	2	2	
54	8A5-47425-00	BRACKET, REAR 2	1	1	

FIG. 25 TRACK SUSPENSION 2

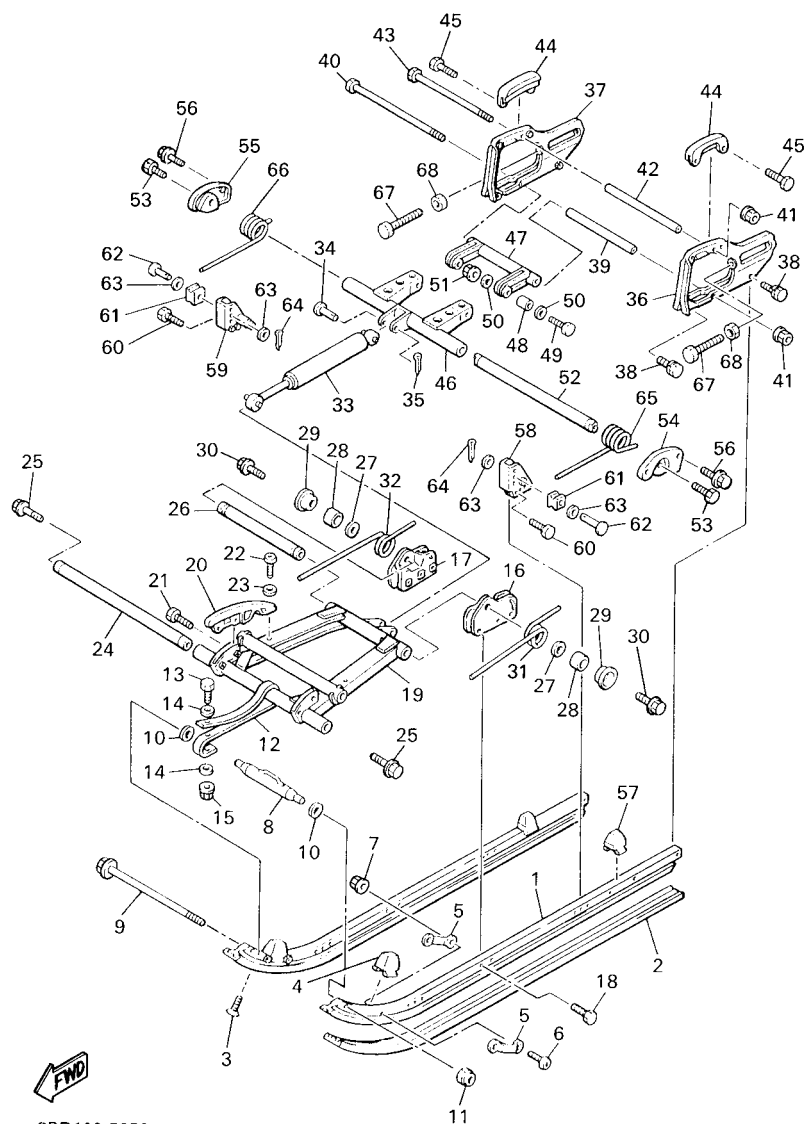

8BD100-5250

REF. NO.	PART NO.	DESCRIPTION	CAN	JPN	REMARKS
55	8A5-47426-00	BRACKET, REAR 1	1	1	
56	95827-08025	BOLT, FLANGE	4	4	
57	8L1-47457-01	DAMPER 2	2	2	
58	8T9-47463-00	BRACKET 5	1	1	
59	8T9-47464-00	BRACKET 6	1	1	
60	90101-06348	BOLT	6	6	
61	890-47447-00	HOOK 2	2	2	
62	90249-12113	PIN	2	2	
63	90201-12749	WASHER, PLATE	4	4	
64	91401-30025	PIN, SPLIT	2	2	
65	90508-99331	SPRING, TORSION	1	1	STD
	90508-99649	SPRING, TORSION	1	1	AP
66	90508-99332	SPRING, TORSION	1	1	STD
	90508-99650	SPRING, TORSION	1	1	AP
67	90101-10314	BOLT	2	2	
68	90179-10279	NUT	2	2	

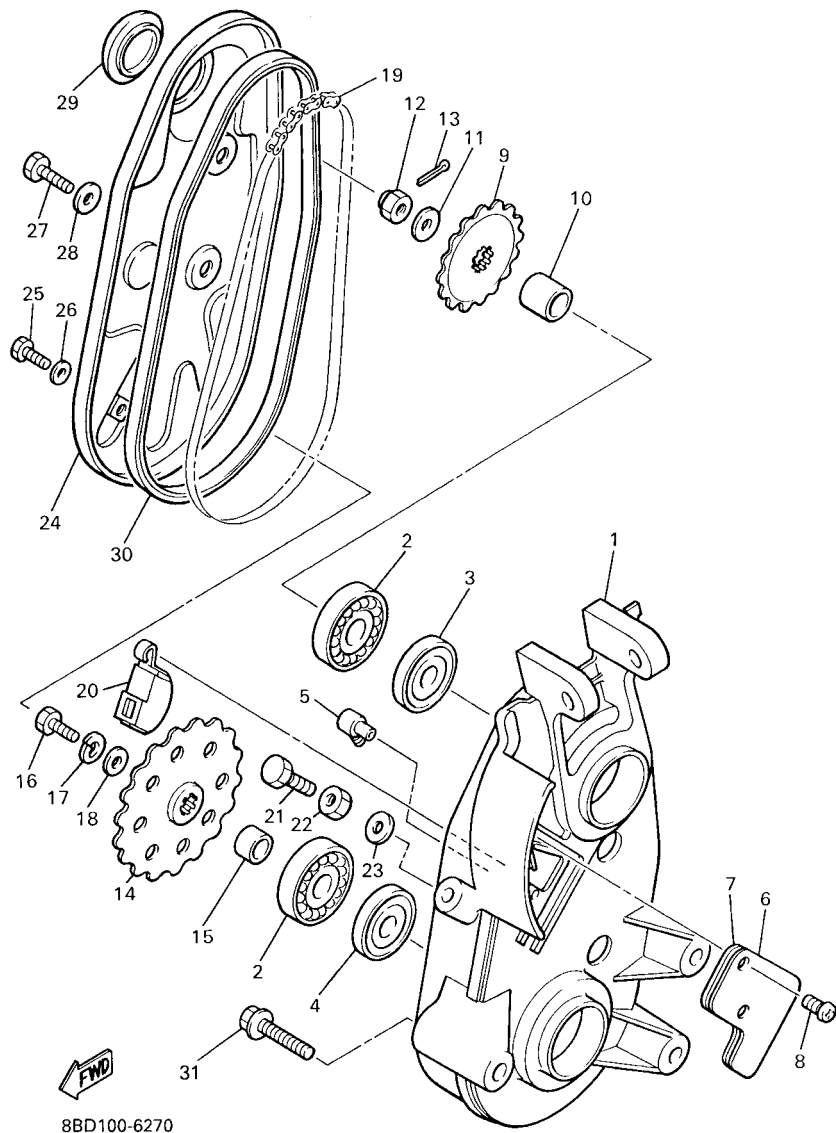
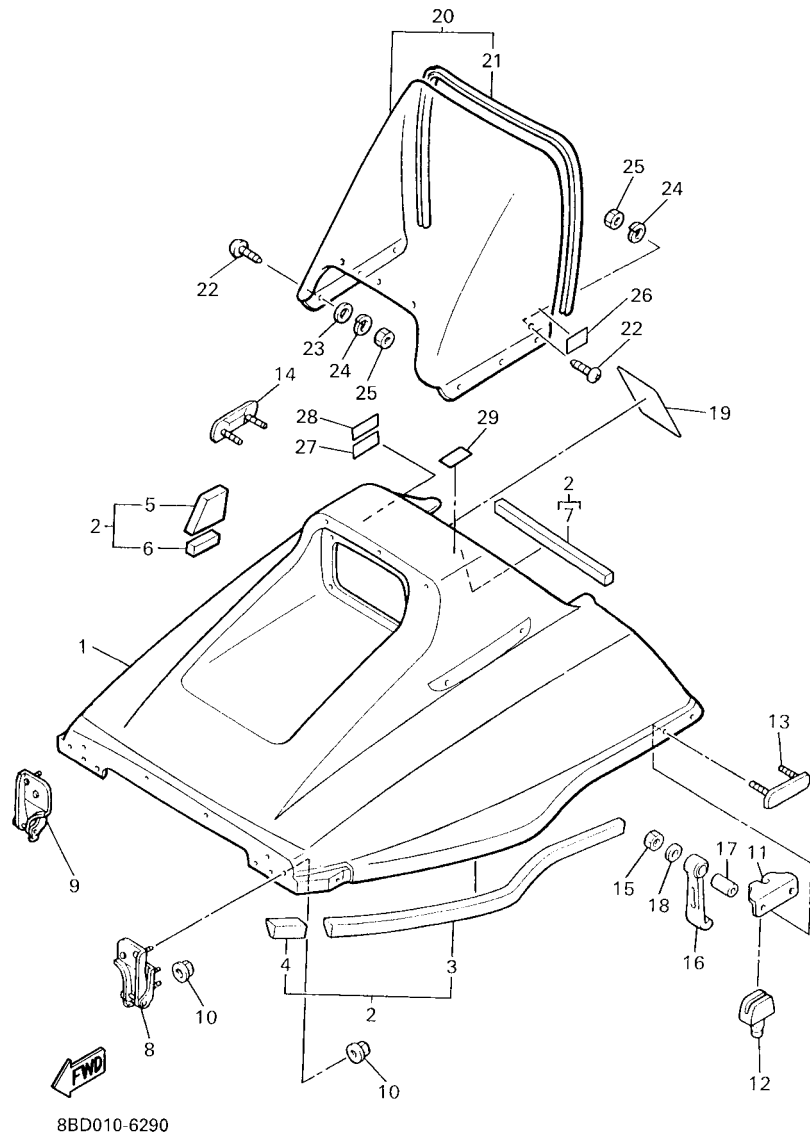

FIG. 27 TRACK DRIVE 2

REF. NO.	PART NO.	DESCRIPTION	CAN	JPN				REMARKS
1	8R4-47541-00	HOUSING, CHAIN	1	1				
2	93306-30407	BEARING (B6304C3)	2	2				
3	93102-25081	OIL SEAL	1	1				
4	93102-20010	OIL SEAL	1	1				
5	89B-47586-00	BREATHER	1	1				
6	8R4-47591-00	PLATE	1	1				
7	86A-47592-00	GASKET	1	1				
8	98907-05016	SCREW, BIND	2	2				
9	812-17682-00	SPROCKET, CHAIN DRIVE(10T)	1	1				STD
	812-17682-10	SPROCKET, CHAIN DRIVE(11T)	1	1				AP
	812-17682-20	SPROCKET, CHAIN DRIVE(12T)	1	1				AP
	812-17682-30	SPROCKET, CHAIN DRIVE(13T)	1	1				AP
	812-17682-40	SPROCKET, CHAIN DRIVE(14T)	1	1				AP
10	90387-197E9	COLLAR	1	1				
11	90201-122H1	WASHER, PLATE	1	1				
12	95307-12600	NUT	1	1				
13	91401-25025	PIN, COTTER	1	1				
14	8BC-47548-40	SPROCKET, CHAIN DRIVEN(24T)	1	1				STD
	8BC-47548-10	SPROCKET, CHAIN DRIVEN(21T)	1	1				AP
	8BC-47548-20	SPROCKET, CHAIN DRIVEN(22T)	1	1				AP
	8BC-47548-30	SPROCKET, CHAIN DRIVEN(23T)	1	1				AP
15	90387-200F1	COLLAR	1	1				
16	97027-08025	BOLT	1	1				
17	92907-08600	WASHER, PLATE	1	1				
18	90201-086A3	WASHER, PLATE	1	1				
19	94580-01044	CHAIN	1	1				
20	8F3-47611-02	TENSIONER	1	1				

FIG. 29 SHROUD & WINDSHIELD



REF. NO.	PART NO.	DESCRIPTION	CAN	JPN			REMARKS
1	8BD-77111-30	SHROUD	1	1			
2	8BD-W7726-00	LINING SET	1	1			
3	8X8-21965-00	.PATCH 5	1	1			
4	80F-21966-00	.PATCH 6	1	1			
5	80F-77261-00	.LINING, SHROUD 1	1	1			
6	80F-77262-00	.LINING, SHROUD 2	1	1			
7	80F-77263-00	.LINING, SHROUD 3	1	1			
8	8R4-77140-00	HINGE ASSY	1	1			
9	8R4-7714A-00	HINGE ASSY 2	1	1			
10	95707-06500	NUT, FLANGE	8	8			
11	8R4-77136-00	CLAMP 2	2	2			
12	8R4-77188-00	STOPPER	2	2			
13	80F-77185-00	PLATE 1	1	1			
14	80F-77186-00	PLATE 2	1	1			
15	95607-06100	NUT, U	4	4			
16	8R4-77171-00	BODY, LATCH 1	2	2			
17	90387-06027	COLLAR	2	2			
18	90201-06380	WASHER, PLATE	2	2			
19	87S-77761-10	LABEL, WARNING 1	1				
	8BC-77761-00	LABEL, WARNING 1		1			
20	80J-77210-10	WINDSHIELD COMP.	1	1			
21	87T-77213-10	.TRIM, UPPER	1	1			
22	90164-05007	SCREW, TAPPING	10	10			
23	92907-05200	WASHER	9	9			
24	92907-05100	WASHER, SPRING	10	10			
25	95307-05600	NUT	10	10			
26	80V-2835Y-90	LABEL, CAUTION		1			

FIG. 29 SHROUD & WINDSHIELD

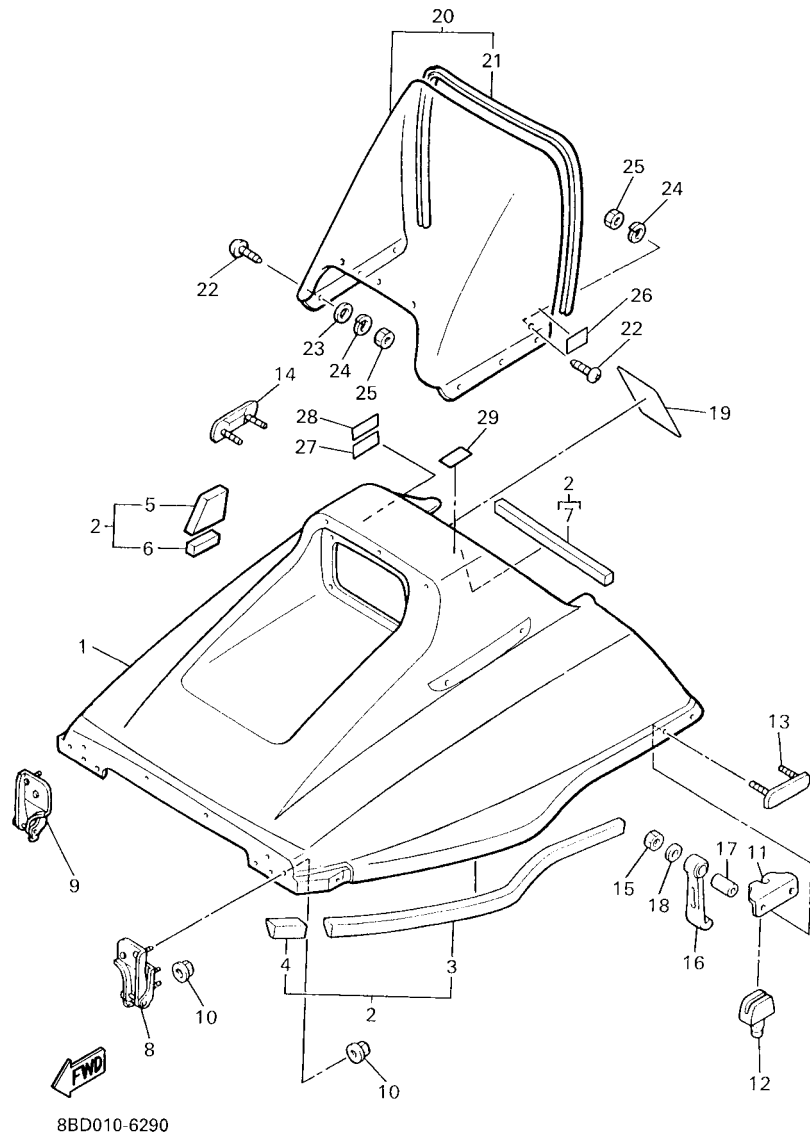

REF. NO.	PART NO.	DESCRIPTION	CAN	JPN				REMARKS
27	8AF-47578-00	LABEL 1	1					
28	8AE-1417E-00	LABEL, CAUTION	1					
29	8M7-77767-00	LABEL, WARNING 7		1				

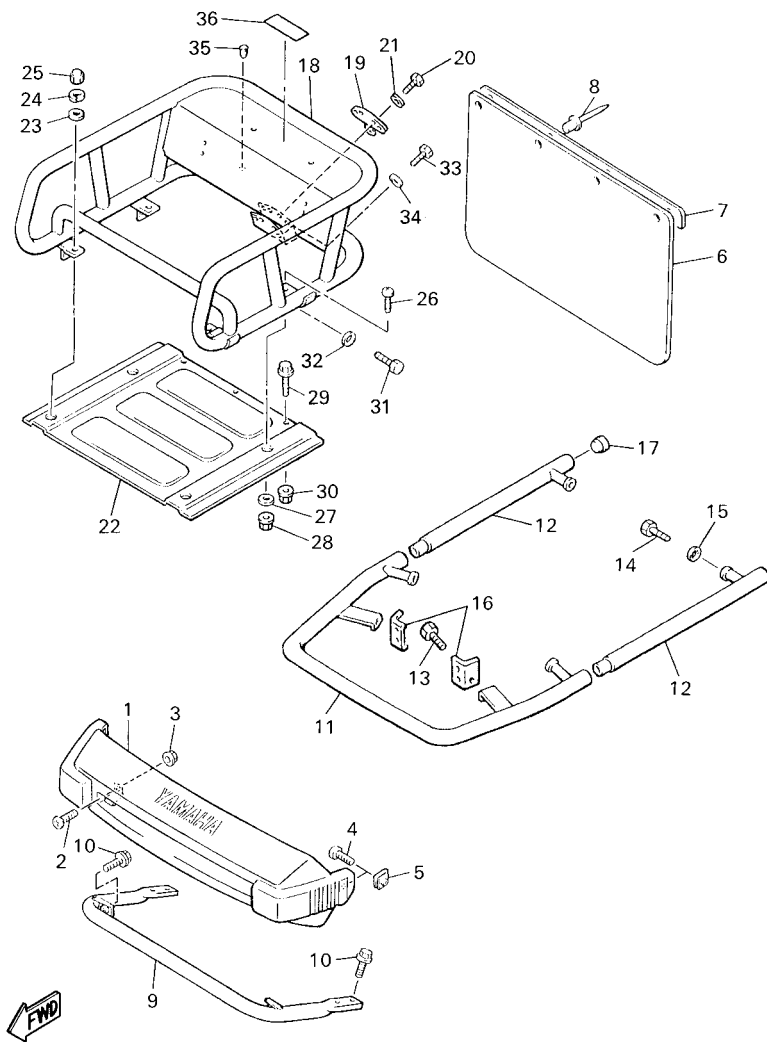

8BD100-7310

FIG. 31 BUMPER

REF. NO.	PART NO.	DESCRIPTION	CAN	JPN	REMARKS
1	81X-77511-00	BUMPER, FRONT 1	1	1	
2	98907-06016	SCREW, BIND	2	2	
3	95707-06500	NUT, FLANGE	2	2	
4	98907-05012	SCREW, BIND	2	2	
5	90183-05013	NUT, SPRING	2	2	
6	8R4-77595-01	FLAP	1	1	
7	80J-77596-00	STOPPER, FLAP	1	1	
8	90267-48086	RIVET, BLIND	4	4	
9	8R4-77513-00	BUMPER, FRONT 3	1	1	
10	95807-08016	BOLT, FLANGE	6	6	
11	8AF-77512-00	BUMPER, FRONT 2	1	1	
12	8AF-77513-00	BUMPER, FRONT 3	2	2	
13	95807-08016	BOLT, FLANGE	2	2	
14	97007-08016	BOLT	4	4	
15	92907-08600	WASHER, PLATE	4	4	
16	84A-77531-01	BRACKET, FRONT	2	2	
17	90338-18176	PLUG	2	2	
18	8Y1-77541-00	BUMPER, REAR 1	1	1	
19	84R-77592-00	BRACKET, HITCH 2	1	1	
20	97027-08020	BOLT	4	4	
21	92907-08600	WASHER, PLATE	4	4	
22	8Y1-77554-00	PROTECTOR 4	1	1	
23	92907-08600	WASHER, PLATE	2	2	
24	92907-08100	WASHER, SPRING	2	2	
25	95307-08800	NUT	2	2	
26	98907-08020	SCREW, BIND	2	2	
27	90201-086A3	WASHER, PLATE	2	2	

FIG. 32 INSTRUMENT PANEL

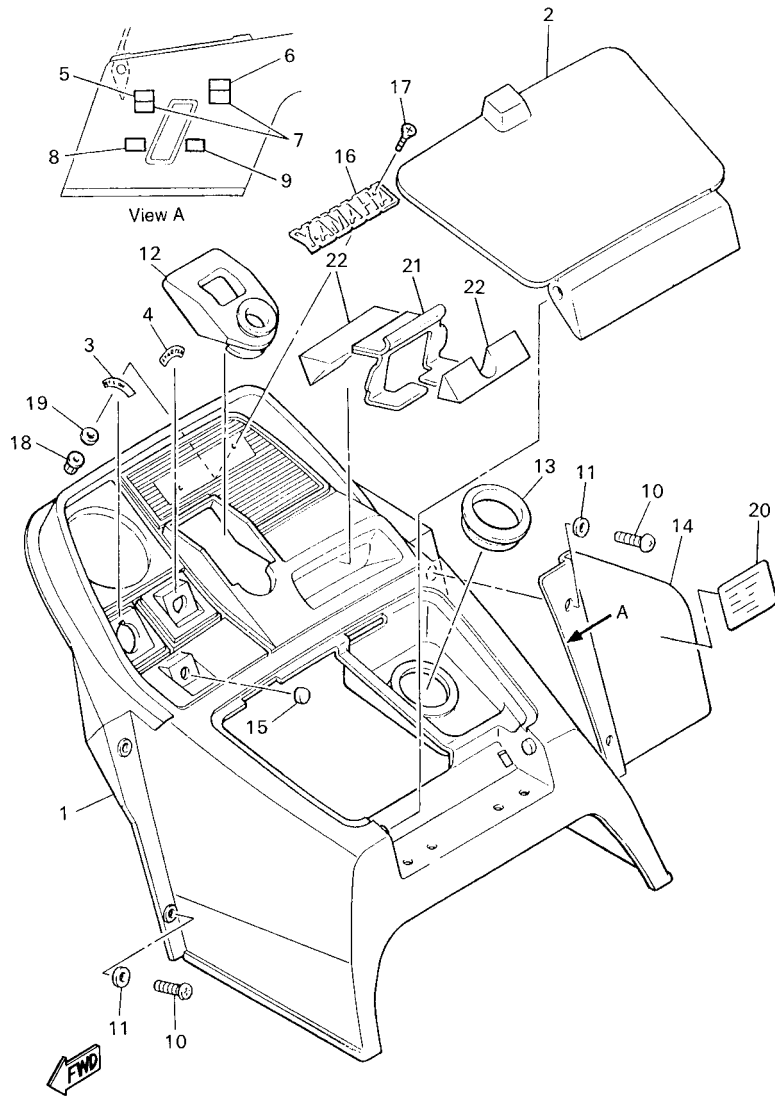

8BD100-7320

REF. NO.	PART NO.	DESCRIPTION	CAN	JPN				REMARKS
1	8Y1-77711-00	PANEL, INSTRUMENT	1					
	81U-77711-90	PANEL, INSTRUMENT		1				
2	8R4-77712-00	PANEL, INSTRUMENT	1	1				
3	8K2-77741-00	INDICATOR 1	1	1				
4	8K4-77742-00	INDICATOR 2	1	1				
5	87A-77742-00	INDICATOR 2	1	1				
6	87A-77743-00	INDICATOR 3	1	1				
7	87A-77741-00	INDICATOR 1	2	2				
8	87A-77745-00	INDICATOR 5	1	1				
9	87A-77744-00	INDICATOR 4	1	1				
10	98507-05016	SCREW, PAN HEAD	4	4				
11	90201-05029	WASHER, PLATE	4	4				
12	8R4-77740-00	GROMMET, INSTRUMENT PANEL	1	1				
13	90480-53313	GROMMET	1	1				
14	8U0-77721-00	BRACKET 1	1	1				
15	90480-12012	GROMMET	1	1				
16	4G7-24161-00	EMBLEM 1		1				
17	98707-04016	SCREW, FLAT HEAD		2				
18	95707-04300	NUT, FLANGE		2				
19	92907-04600	WASHER		2				
20	8Y1-77762-70	LABEL, WARNING 2	1	1				
21	80F-23881-00	BRACKET 1	1	1				
22	80F-23858-00	SPACER	2	2				

FIG. 33 GENERATOR

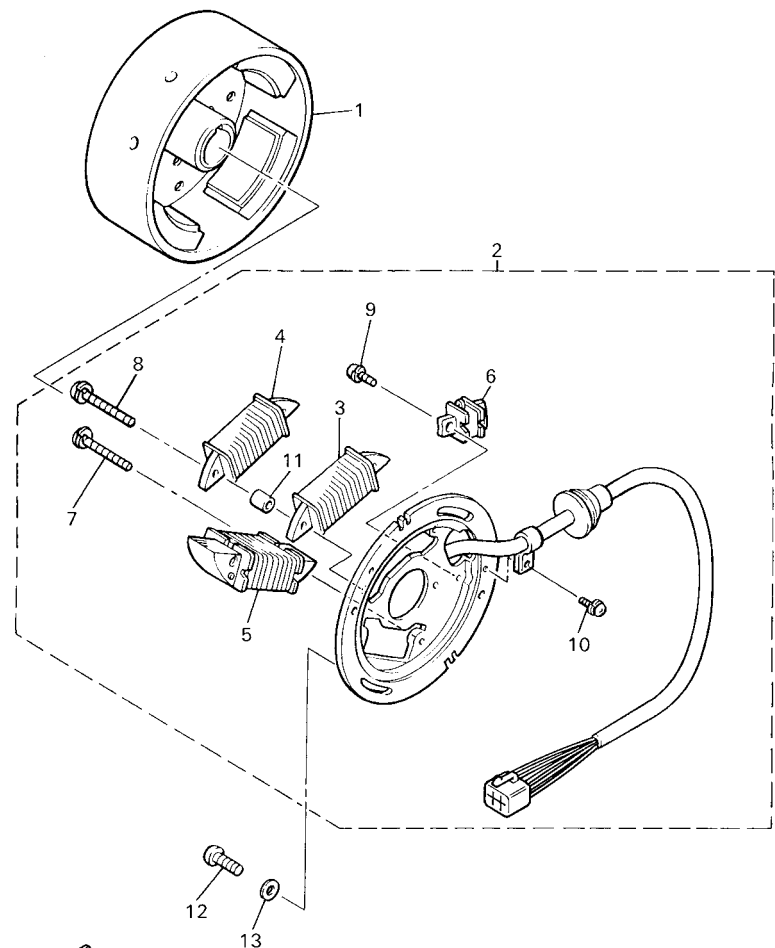

8BD100-5320

REF. NO.	PART NO.	DESCRIPTION	CAN	JPN	REMARKS
1	85L-85550-01	ROTOR ASSY	1	1	
2	8BD-85560-00	BASE ASSY	1	1	
3	81L-85520-M0	.COIL, CHARGE	1	1	
4	81L-81314-M0	.COIL, LIGHTING 2	1	1	
5	82H-81313-M0	.COIL, LIGHTING 1	1	1	
6	8R4-85580-M0	.COIL, PULSER	1	1	
7	90159-05129	.SCREW, WITH WASHER	2	2	
8	90159-05130	.SCREW, WITH WASHER	2	2	
9	97602-04112	.SCREW, PAN HEAD WITH WASHER	2	2	
10	97602-04108	.SCREW, PAN HEAD WITH WASHER	1	1	
11	90387-06299	.COLLAR	2	2	
12	90154-06035	SCREW, BINDING	2	2	
13	90201-06043	WASHER, PLATE	2	2	

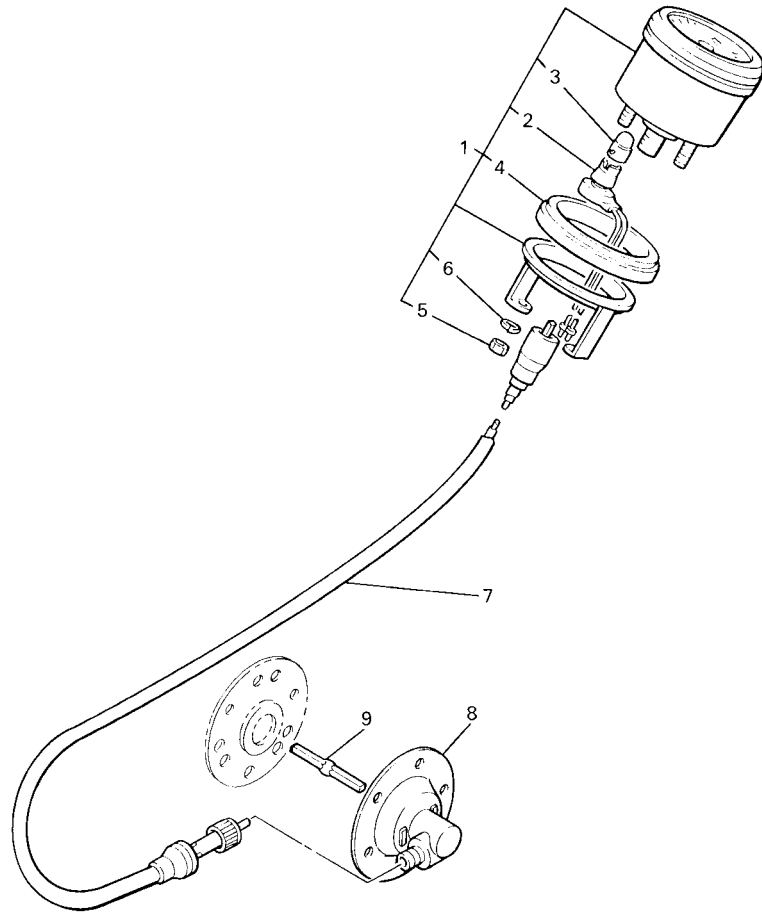

8BD5100-8340

FIG. 34 METER

REF. NO.	PART NO.	DESCRIPTION	CAN	JPN		REMARKS
1	80V-83510-20	SPEEDOMETER ASSY (KM/H)	1	1		
2	8V7-83536-40	.SOCKET, METER	1	1		
3	4R0-83517-00	.BULB (12V-3.4W T10)	1	1		
4	8G6-83523-00	.DAMPER	1	1		
5	95307-05600	.NUT	2	2		
6	92907-05100	.WASHER, SPRING	2	2		
7	8Y8-83550-00	SPEEDOMETER CABLE ASSY	1	1		
8	8Y1-47700-00	METER GEAR HOUSING COMP.	1	1		
9	8K4-47715-00	JOINT	1	1		

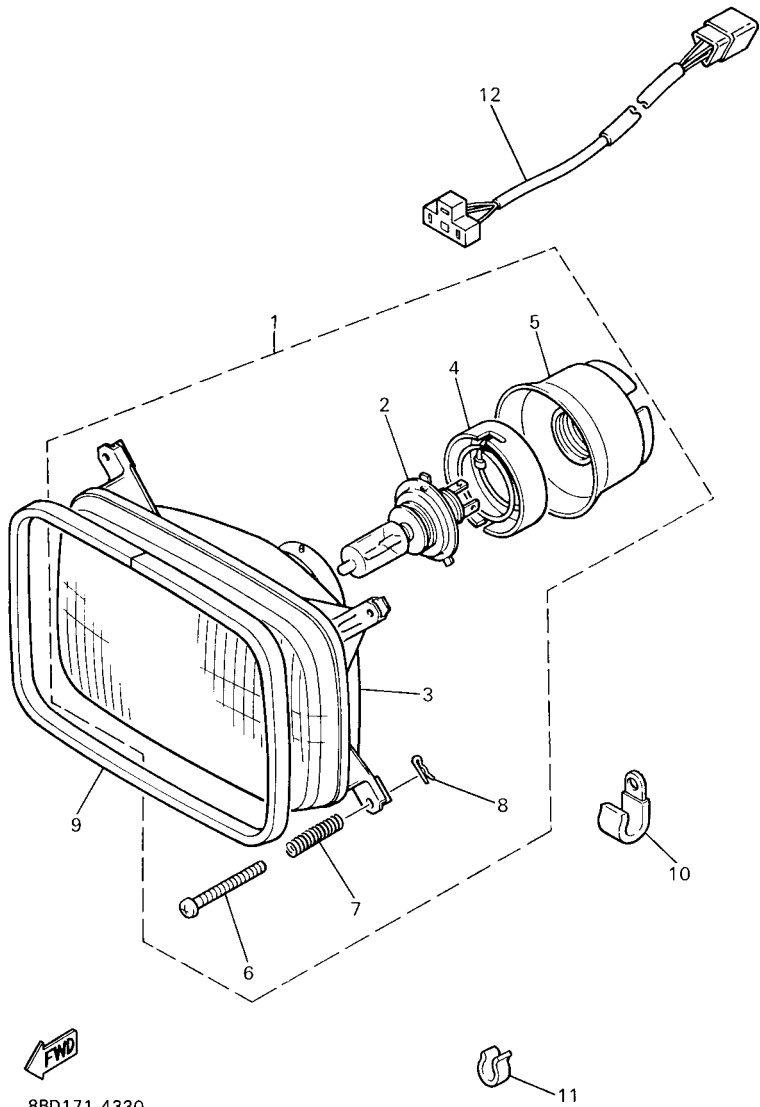
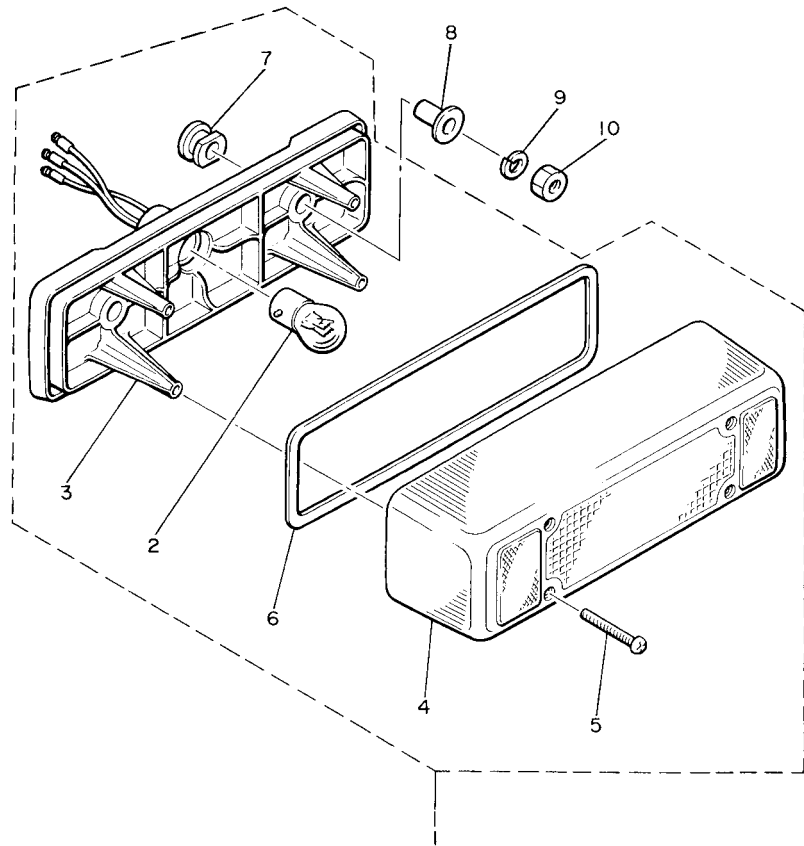

FIG. 35 HEADLIGHT

REF. NO.	PART NO.	DESCRIPTION	CAN	JPN			REMARKS
1	8G9-84310-00	HEADLIGHT UNIT ASSY	1	1			
2	8V0-84314-10	.BULB, HEADLIGHT (12V-60/55W)	1	1			(H4)HALOGEN
3	8A7-84320-00	.LENS ASSY	1	1			
4	8A7-84312-00	.HOLDER, SOCKET	1	1			
5	8A7-84397-01	.COVER, SOCKET	1	1			
6	8A5-84331-00	.SCREW, RIM ADJUSTING	4	4			
7	8A5-84332-00	.SPRING, SCREW	4	4			
8	807-84374-00	.CLIP	4	4			
9	8T7-84366-00	DAMPER, HEADLIGHT 1	1	1			
10	90465-08028	CLAMP	1	1			
11	90468-05176	CLIP	1	1			
12	8AD-84359-00	CORD, HEADLIGHT	1	1			

FIG. 36 TAILLIGHT



80E100-5330

REF. NO.	PART NO.	DESCRIPTION	CAN	JPN				REMARKS
1	8K4-84710-00	TAILLIGHT UNIT ASSY	1	1				
2	838-84714-01	.BULB (12V-23/8W)	1	1				
3	8K4-84711-00	.BASE, TAILLIGHT	1	1				
4	8K4-84721-00	.LENS, TAILLIGHT	1	1				
5	97701-40130	.SCREW, PANHEAD TAPPING	4	4				
6	87M-84723-00	.GASKET, TAIL LENS	1	1				
7	8K4-84718-00	.GROMMET	2	2				
8	90387-066N1	COLLAR	2	2				
9	92907-06100	WASHER, SPRING	2	2				
10	95307-06600	NUT	2	2				

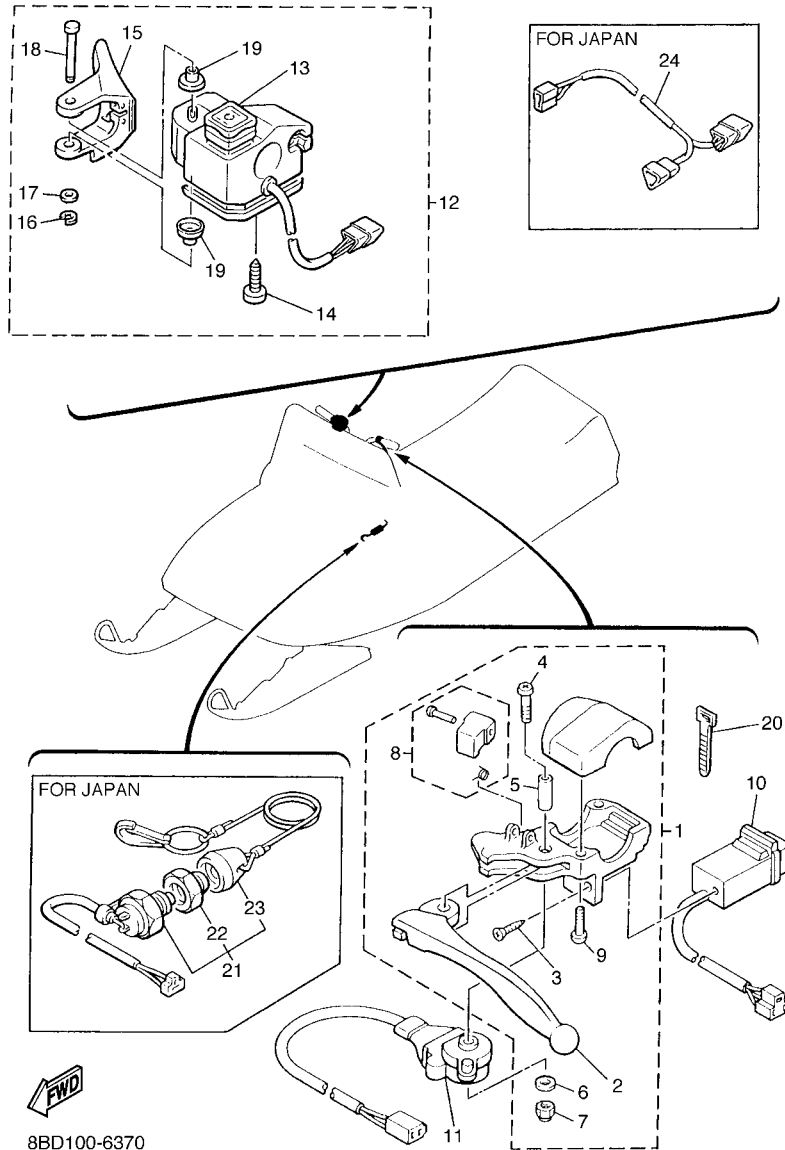
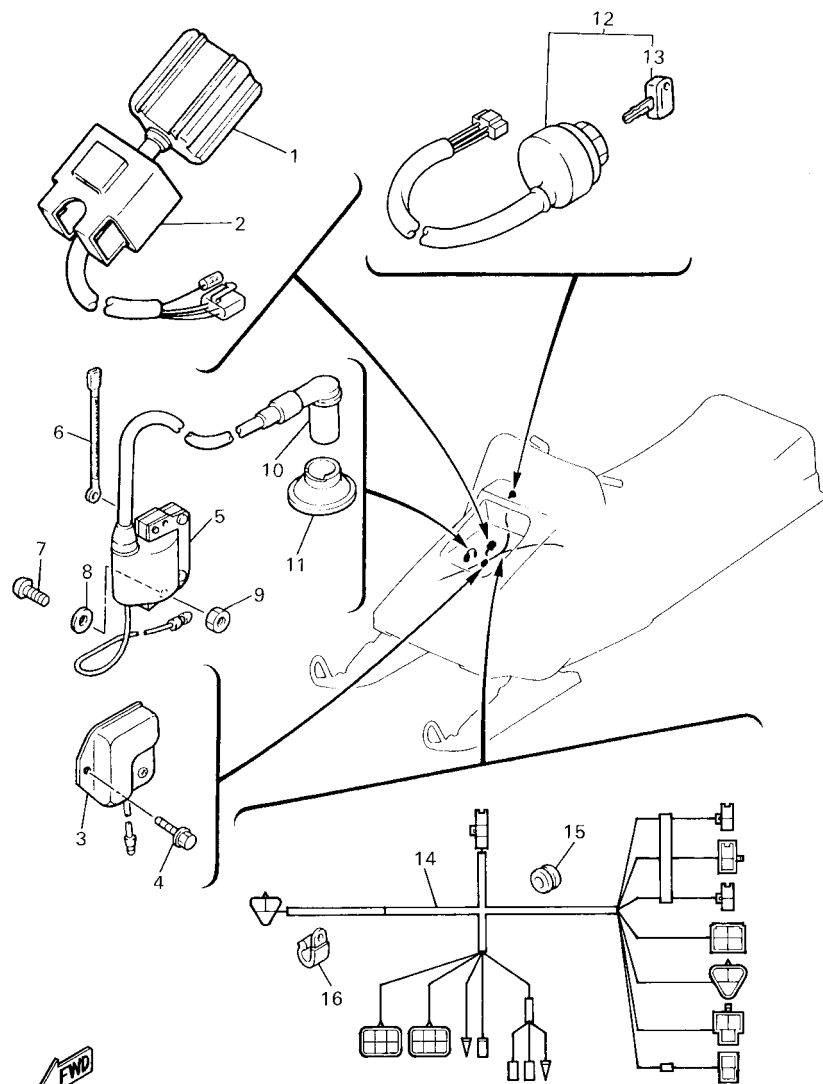

FIG. 37 HANDLE SWITCH & LEVER

REF. NO.	PART NO.	DESCRIPTION	CAN	JPN	REMARKS
1	8E3-W8291-01	LEVER HOLDER ASSY (LEFT)	1	1	
2	803-83912-00	.LEVER 1	1	1	
3	97701-30712	.SCREW, TAPPING	1	1	
4	90157-05114	.SCREW, PAN HEAD	1	1	
5	802-83913-00	.COLLAR, LEVER 1	1	1	
6	92990-05200	.WASHER, PLAIN	1	1	
7	95701-05300	.NUT, NYLON	1	1	
8	8E3-83930-01	.LEVER LOCK ASSY	1	1	
9	90157-05027	.SCREW, PAN HEAD	2	2	
10	8H8-83950-01	BEAM SWITCH ASSY	1	1	
11	8R4-82530-00	STOP SWITCH ASSY	1	1	
12	8AD-82720-00	LEVER HOLDER ASSY (RIGHT)	1	1	
13	8AD-82575-09	.ENGINE STOP SWITCH ASSY	1	1	
14	8R6-83928-00	.SCREW	1	1	
15	8V0-42138-00	.LEVER, THROTTLE	1	1	
16	99001-04600	.CIRCLIP	1	1	
17	85G-83663-00	.WASHER, SPECIAL	1	1	
18	8R6-8399F-00	.SHAFT	1	1	
19	85G-83956-00	.CAP 1	2	2	
20	437-83936-01	BAND, SWITCH CORD	4	4	
21	8H8-82550-01	ENGINE STOP SWITCH ASSY	1		AP
22	8H8-82557-00	.NUT	1		AP
23	8H7-82552-01	.CAP, SWITCH	1		AP
24	89L-82318-00	WIRE, SUB-LEAD	1		AP

FIG. 38 ELECTRICAL 1



8BD100-5360

REF. NO.	PART NO.	DESCRIPTION	CAN	JPN	REMARKS
1	8AU-85540-00	C.D.I. UNIT ASSY	1	1	
2	2A7-85546-00	BAND	1	1	
3	82M-81910-A0	VOLTAGE REGULATOR ASSY	1	1	
4	95807-06012	BOLT, FLANGE	2	2	
5	86B-82310-10	IGNITION COIL ASSY	1	1	
6	83Y-82318-00	WIRE, SUB-LEAD	1	1	
7	97880-06040	SCREW, PAN HEAD	2	2	
8	92990-06600	WASHER, PLATE	2	2	
9	95307-06600	NUT	2	2	
10	8K1-82370-20	PLUG CAP ASSY (WITH RESISTOR)	1	1	
11	8G5-82372-00	SEAL, PLUG CAP	1	1	
12	8R4-82510-20	MAIN SWITCH ASSY	1	1	
13	526-82579-00	.CAP, KEY	1	1	
14	8BD-82590-00	WIRE HARNESS ASSY	1	1	
15	90480-16422	GROMMET	1	1	
16	90465-08028	CLAMP	2	2	

FIG. 39 ELECTRICAL 2

REF. NO.	PART NO.	DESCRIPTION	CAN	JPN				REMARKS
1	86R-85110-00	REFLECTOR ASSY	2	2				
2	80F-85115-00	BASE, REFLECTOR	2	2				
3	95707-05500	NUT, FLANGE	4	4				
4	81G-85130-00	REAR REFLECTOR ASSY	2	2				

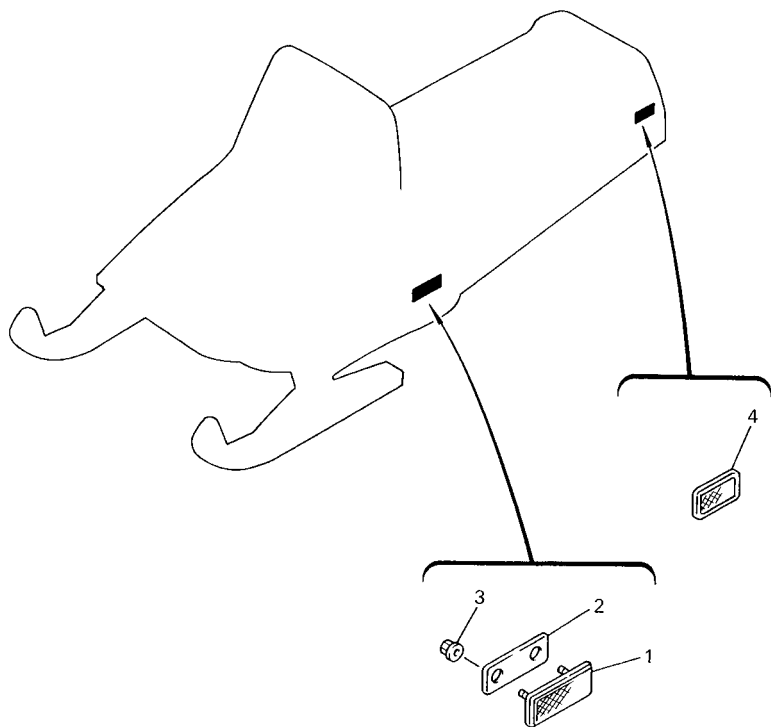

8BD100-6390

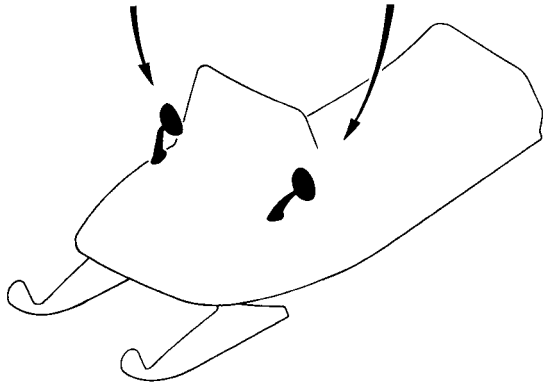
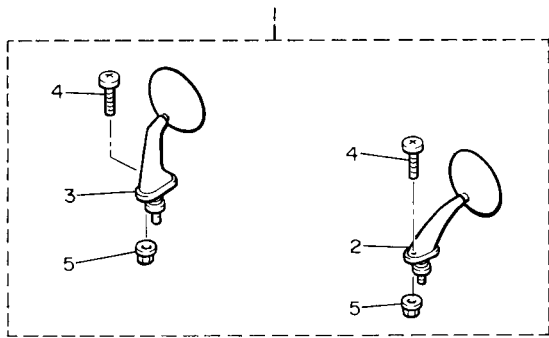

88U100-1400

FIG. 40 ALTERNATE REAR VIEW MIRROR

REF. NO.	PART NO.	DESCRIPTION	CAN	JPN				REMARKS
1	8E1-W2628-00	REAR VIEW MIRROR SET	1	1				AP
2	8E1-26280-00	.REAR VIEW MIRROR ASSY (LEFT)	1	1				
3	8E1-26290-00	.REAR VIEW MIRROR ASSY(RIGHT)	1	1				
4	98507-04016	.SCREW, PAN HEAD	4	4				
5	95707-04500	.NUT, FLANGE	4	4				

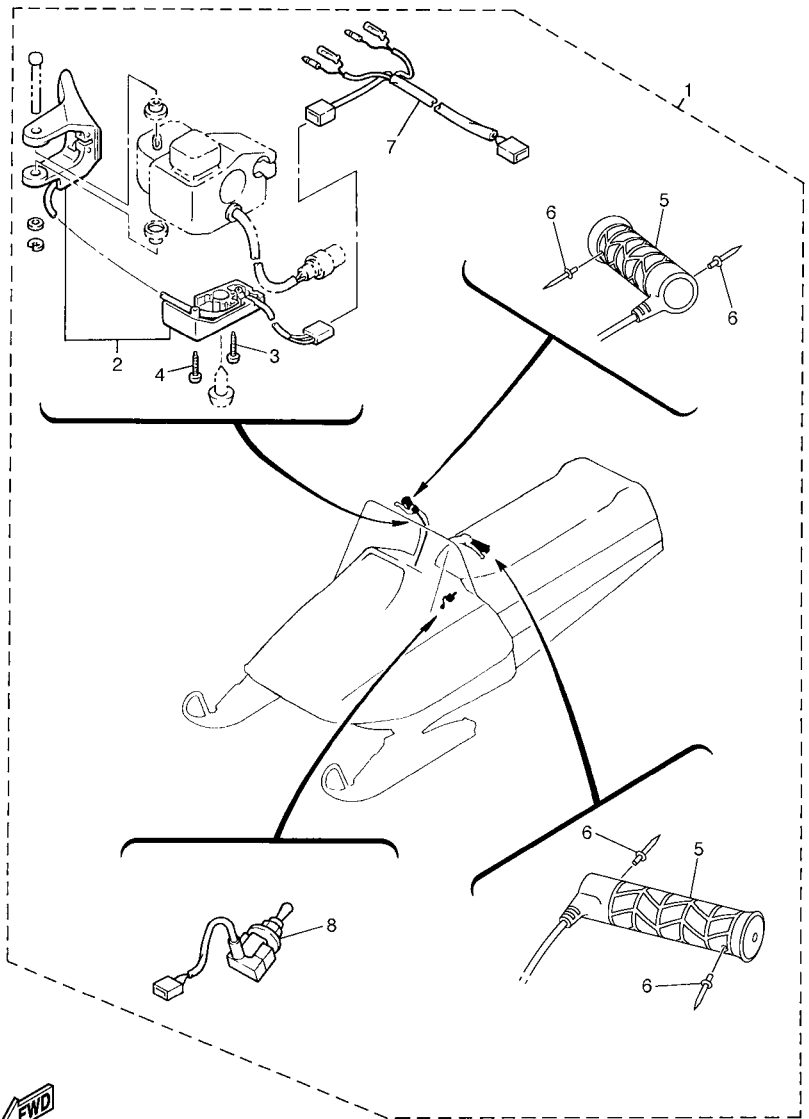

8BDC100-D410

FIG. 41 ALTERNATE THUMB WARMER KIT

REF. NO.	PART NO.	DESCRIPTION	CAN	JPN		REMARKS
1	8BD-W8293-02	THUMB WARMER KIT	1	1		AP
2	8AU-82970-02	.THUMB WARMER ASSY	1	1		
3	97706-30620	.SCREW, TAPPING	1	1		
4	97707-30630	.SCREW, TAPPING	1	1		
5	8DX-26240-00	.GRIP ASSY	2	2		
6	90267-48014	.RIVET, BLIND	4	4		
7	8BD-82318-00	.WIRE, SUB-LEAD	1	1		
8	8BE-82917-00	.SWITCH	1	1		

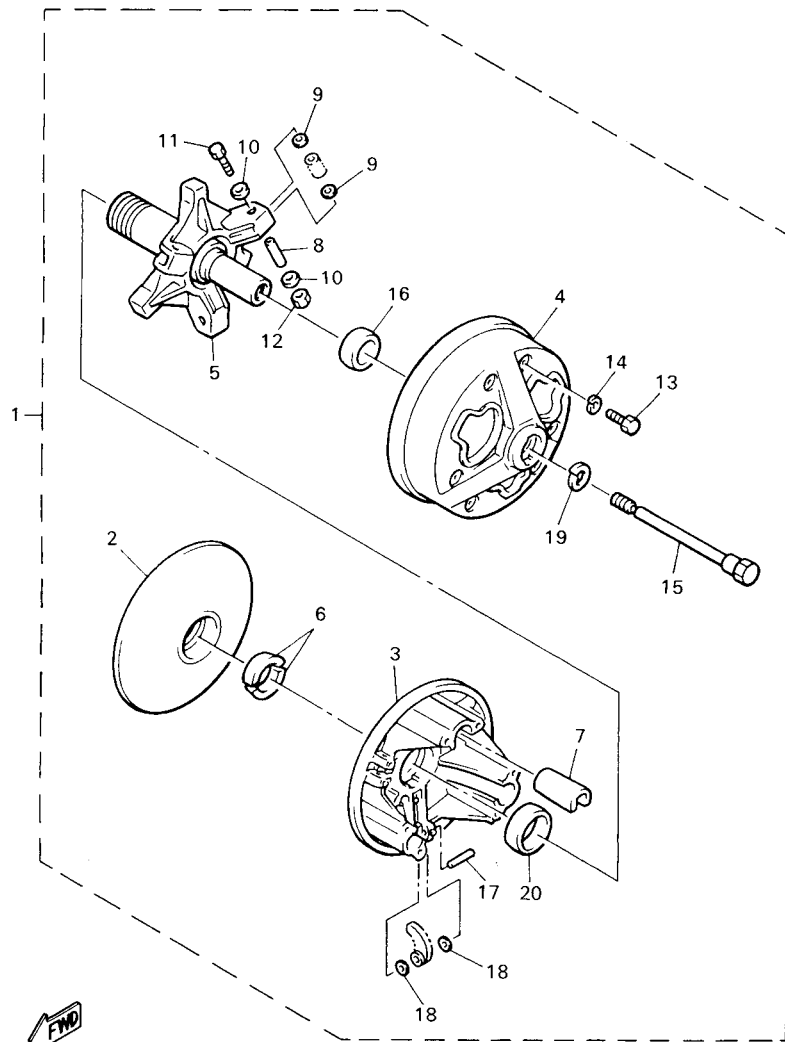

8BD8100-1420

FIG. 42 ALTERNATE REBUILD KIT

REF. NO.	PART NO.	DESCRIPTION	CAN	JPN	REMARKS
1	89X-17601-09	CLUTCH REPAIR KIT	1	1	AP
2	84J-17611-00	.SHEAVE, PRIMARY FIXED	1	1	
3	8V0-17621-01	.SHEAVE, PRIMARY SLIDING	1	1	
4	8V0-17631-00	.CAP	1	1	
5	8V0-17640-02	.SPIDER COMPLETE	1	1	
6	8V0-17639-00	.STOPPER	2	2	
7	88X-17653-00	.SLIDER	3	3	
8	90387-057W5	.COLLAR	3	3	
9	90202-08205	.WASHER, PLATE	6	6	
10	90201-050P9	.WASHER, PLATE	6	6	
11	97027-05035	.BOLT	3	3	
12	95617-05100	.NUT, U	3	3	
13	97017-06030	.BOLT	6	6	
14	92907-06600	.WASHER, PLATE	6	6	
15	8V0-17647-00	.BOLT (L=156.5MM)	1	1	
16	90389-28032	.BUSH	1	1	
17	93607-44190	.PIN, DOWEL	3	3	
18	90201-077F5	.WASHER, PLATE	6	6	
19	92907-16100	.WASHER	1	1	
20	90389-40029	.BUSH	1	1	

FIG. 43 ALTERNATE CLUTCH TUNE UP KIT

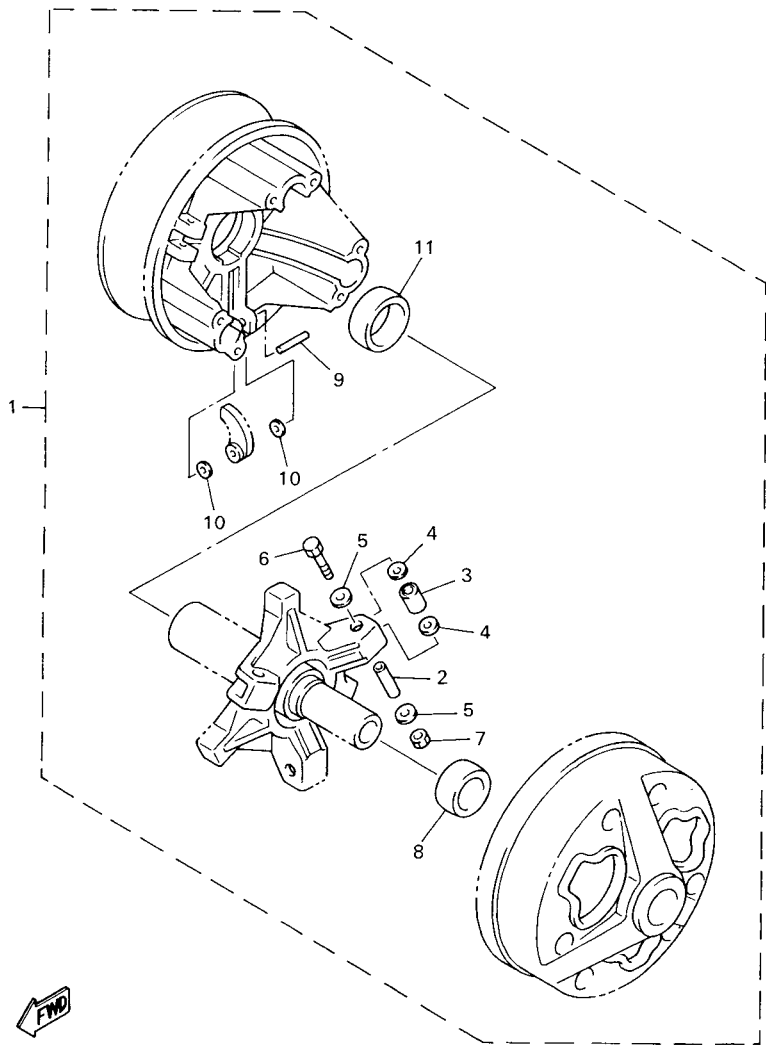

8BD8100-1430

REF. NO.	PART NO.	DESCRIPTION	CAN	JPN				REMARKS
1	89D-00000-50	CLUTCH TUNE-UP KIT (T)	1	1				AP
2	90387-057W5	.COLLAR	3	3				
3	90387-087W7	.COLLAR	3	3				
4	90202-08205	.WASHER, PLATE	6	6				
5	90201-050P9	.WASHER, PLATE	6	6				
6	97022-05035	.BOLT	3	3				
7	95612-05100	.NUT, U	3	3				
8	90389-28032	.BUSH	1	1				
9	93607-44190	.PIN, DOWEL	3	3				
10	90201-077F5	.WASHER, PLATE	6	6				
11	90389-40029	.BUSH	1	1				

NUMERICAL INDEX

PART NO.	GRID NO.	PART NO.	GRID NO.	PART NO.	GRID NO.	PART NO.	GRID NO.	PART NO.	GRID NO.	PART NO.	GRID NO.
89D-00000-50	E - 13	8A6-14516-00	B - 10	8V0-17640-02	E - 12	8J6-23350-00	C - 7	813-24613-01	C - 11	888-47456-01	D - 4
J38-11116-00	B - 12	8A6-14516-02	B - 10	89X-17641-00	B - 14	86C-23710-00	C - 6	83M-24628-00	C - 10	8L1-47457-01	D - 6
8R4-11311-02	B - 2	8A6-14516-05	B - 10	8V0-17647-00	B - 14	8E3-23731-01	C - 6		C - 11	885-47458-01	D - 4
8R4-11351-04	B - 2	8G6-14521-00	B - 9		E - 12	888-23735-00	C - 6	89A-24641-00	C - 10	8L1-47461-00	D - 2
8R4-11400-00	B - 3	8E7-14546-00	B - 9	88X-17653-00	B - 14	8R4-23760-10	C - 6		C - 11	8T9-47463-00	D - 6
8R4-11412-00	B - 3	676-14548-00	B - 9		E - 12	8F3-23761-10	C - 6	8BD-2470F-01	C - 13	8T9-47464-00	D - 6
8R4-11422-00	B - 3	80F-14610-00	B - 11	8R4-17660-00	B - 15	8F3-23762-10	C - 6	8BD-24710-01	C - 13	8A5-47465-02	D - 4
8R4-11610-00	B - 3	8R4-14612-00	B - 11	8R4-17670-01	B - 15	8F3-23763-10	C - 6	4KN-24877-C0	D - 15	80E-47471-01	D - 5
8R4-11610-10	B - 3	8R4-14613-01	B - 11	8R4-17681-01	B - 15	8G6-23766-00	C - 6	89X-24897-00	D - 15	80E-47472-01	D - 5
8R4-11610-20	B - 3	888-14633-00	B - 11	812-17682-00	D - 8	878-23768-00	C - 6	8R4-25711-00	C - 14	8A5-47475-02	D - 5
8R4-11631-00-96	B - 3	8G6-14948-18	B - 9	812-17682-10	D - 8	8R4-23770-10	C - 6	8BC-25730-00	C - 14	8E7-47480-00	D - 5
818-11633-00	B - 3	8A6-14969-00	B - 9	812-17682-20	D - 8	86A-23811-90	C - 8	8BC-25740-00	C - 14	8A5-47485-02	D - 4
8R4-11635-00	B - 3	8A6-14977-00	B - 9	812-17682-30	D - 8	8F3-23812-00	C - 8	8J7-25848-00	C - 14	888-47495-02	D - 4
8R4-11636-00	B - 3	8G6-14984-00	B - 9	812-17682-40	D - 8	8R4-23813-00	C - 8	8DX-26240-00	E - 11	8E3-47521-00	D - 2
8R4-11651-00	B - 3	8G6-14985-01	B - 9	8R4-17684-00	B - 15	8G5-23814-00	C - 8	801-26241-01	C - 15	8L4-47530-00	D - 2
8F3-11681-00	B - 3	8M7-14992-00	B - 9	8R4-17688-00	B - 15	8K1-23814-00	C - 8	8E1-26280-00	E - 10	8E3-47531-00	D - 7
8G8-12611-01	B - 4	371-14993-60	B - 9	8R4-21411-00	C - 2	8F3-23818-00	C - 8	8E1-26290-00	E - 10	8R4-47541-00	D - 8
8R4-12651-03	B - 4	8R4-14994-00	B - 9	86A-21419-00	C - 2	8R4-23821-00	C - 8	83Y-26311-01	C - 15	8R4-47543-00	D - 9
8R4-12652-02	B - 4	8R4-15100-01	B - 12	8R4-21485-00	C - 2	86X-23841-00	C - 8	81E-26320-00	B - 5	8BC-47548-10	D - 8
81E-13101-01	B - 5	8R4-15416-00	B - 6	8F3-21486-00	C - 2	86X-23845-00	C - 8	80F-26331-00	C - 15	8BC-47548-20	D - 8
8Y0-13116-01	B - 5	8R4-15426-00	B - 6	8V7-21486-00	C - 2	88P-23851-00	C - 8	8L2-26331-00	C - 15	8BC-47548-30	D - 8
137-13137-00-03	B - 5	8R4-15710-01	B - 13	8R4-21488-01	C - 2	8Y1-23853-00	C - 8	8G8-26333-00	C - 15	8BC-47548-40	D - 8
137-13137-00-05	B - 5	8R4-15711-00	B - 13	8R4-21751-00	C - 3	8Y1-23854-00	C - 8	8R4-26340-00	C - 15	8F3-47551-00	D - 7
137-13137-00-10	B - 5	8F3-15713-01	B - 13	863-21771-00	C - 3	80F-23858-00	E - 2	8J5-26352-00	B - 7	8R4-47558-00	D - 9
137-13138-01	B - 5	8F3-15714-01	B - 13	8V7-21776-00	C - 3	84M-23868-00	C - 8	85L-28100-00	D - 13	8K4-47577-00	D - 7
8A5-13146-01	B - 5	8F3-15715-00	B - 13	8F3-21794-00	C - 9	8BD-23871-00	C - 9	80V-2835Y-90	D - 11	8AF-47578-00	D - 12
137-13148-00	B - 6	8G5-15716-00	B - 13	8V7-21871-00	C - 3	8Y4-23872-00	C - 8	8V0-42138-00	E - 7	89B-47586-00	D - 8
8R4-13175-00	B - 6	8F3-15716-03	B - 13	8BD-21910-00	C - 4	80F-23881-00	E - 2	8BD-47110-00	D - 2	8R4-47591-00	D - 8
821-13176-00	B - 6	81L-15723-00	B - 13	8AB-21945-00	D - 13	8R4-23891-00	C - 4	87M-47320-00	D - 2	86A-47592-00	D - 8
8R4-13178-00	B - 3	8F3-15734-00	B - 13	8V7-21961-00	C - 4	8AE-23892-00	C - 9	8H8-47320-00	D - 2	8F3-47611-02	D - 8
8R4-13188-00	B - 6	8G5-15739-00	B - 13	8V7-21962-00	C - 4	8AC-23894-00	C - 8	89D-47331-00	D - 4	8R4-47631-00	B - 15
353-13552-01	B - 5	8F3-15739-01	B - 13	8V7-21963-00	C - 4	8R4-24111-02	C - 10	8A5-47332-00	D - 5	8Y1-47700-00	E - 4
8R4-13555-00	B - 7	8F3-15741-01	B - 13	82X-21964-00	C - 4	4G7-24161-00	E - 2	8E3-47384-00	D - 2	8K4-47715-00	E - 4
80F-14101-01	B - 9	8F3-15751-00	B - 13	8X8-21965-00	D - 11	8R4-24186-00	C - 10	80E-47411-00	D - 4	8BD-77111-30	D - 11
80J-14101-01	B - 9	8R4-15755-00	B - 13	80F-21966-00	D - 11	8BD-24211-00	C - 11	8E3-47412-00	D - 5	8R4-77118-00	B - 13
80F-14121-00	B - 9	8F3-15758-00	B - 13	80F-21967-00	C - 4	8F3-24327-00	C - 10	8E3-47413-00	D - 5	8R4-77136-00	D - 11
80F-14131-00	B - 9	8R4-15780-00	D - 13	84A-21982-00	C - 4	8X8-24360-01	B - 7	899-47415-00	D - 4	8R4-77140-00	D - 11
80F-14133-00	B - 9	8R4-15788-01	B - 13	84A-21983-00	C - 4	801-24376-00	C - 10	85A-47416-00	D - 4	8BC-77141-60	D - 10
80F-14137-00	B - 9	89X-17601-09	E - 12	80F-21988-00	C - 4	8H8-24376-00	C - 3	8A5-47417-00	D - 5	8BD-77141-70	D - 10
80F-14146-00	B - 9	84J-17611-00	B - 14	80F-21989-00	C - 5	815-24379-00	B - 8	85A-47419-00	D - 4	8R4-7714A-00	D - 11
663-14159-00	B - 9		E - 12	8V7-2198F-00	C - 4	8A5-24410-02	B - 7	8X0-47421-00	D - 4	8BD-77163-70	D - 10
8E7-14161-00	B - 9	8V0-17621-01	B - 14	80F-2198G-00	C - 4	8BD-24500-00	C - 11	8E3-47422-00	D - 5	8BD-77164-70	D - 10
8AE-1417E-00	D - 12		E - 12	8U0-2198G-00	C - 8	22F-24514-01	C - 10	8G8-47422-00	D - 4	8R4-77171-00	D - 11
8A5-14423-00	C - 9	8V0-17631-00	B - 14	8V7-2198G-00	C - 4		C - 11	8A5-47425-00	D - 5	8M6-77175-00	C - 4
8R4-14431-00	B - 7		E - 12	80F-21998-00	C - 4	8BD-24544-00	C - 12	8A5-47426-00	D - 6	80F-77185-00	D - 11
8R4-14441-01	B - 7	8V0-17639-00	B - 14	8Y1-21998-00	C - 8	8A5-24611-00	C - 10	890-47447-00	D - 6	80F-77186-00	D - 11
8R4-14453-00	B - 7		E - 12	80F-2199H-00	C - 4		C - 11	8T9-47451-00	D - 2	8R4-77188-00	D - 11
8A6-14515-98	B - 10	8V0-17640-02	B - 14	8J5-22315-00	D - 9	813-24613-01	C - 10	8V5-47451-00	D - 2	8V7-77198-01	C - 4

NUMERICAL INDEX

PART NO.	GRID NO.	PART NO.	GRID NO.	PART NO.	GRID NO.	PART NO.	GRID NO.	PART NO.	GRID NO.	PART NO.	GRID NO.
80J-77210-10	D - 11	8K1-82370-20	E - 8	8AU-85540-00	E - 8	90185-10085	C - 6	90267-48060	C - 4	90445-114J7	B - 8
87T-77213-10	D - 11	8G5-82372-00	E - 8	2A7-85546-00	E - 8		C - 8		D - 13	90445-114J9	C - 11
80F-77261-00	D - 11	8R4-82510-20	E - 8	85L-85550-01	E - 3	90185-12061	B - 15	90267-48086	D - 14	90445-115K4	B - 7
80F-77262-00	D - 11	8R4-82530-00	E - 7	8BD-85560-00	E - 3	90201-03313	C - 10	90267-48095	C - 12	90445-116G8	B - 7
80F-77263-00	D - 11	8H8-82550-01	E - 7	8R4-85580-M0	E - 3		C - 11	90280-05013	B - 3	90446-08201	B - 5
8R4-77311-00	D - 13	8H7-82552-01	E - 7	8V8-W176A-00	B - 14	90201-05029	E - 2	90282-05047	B - 15	90460-50079	D - 7
8BD-77338-00	C - 5	8H8-82557-00	E - 7	8E1-W2628-00	E - 10	90201-050P9	B - 14	90338-09127	C - 4	90460-51059	B - 7
8BD-77351-60	D - 10	8AD-82575-09	E - 7	85A-W4751-00	D - 7		E - 12	90338-10132	C - 3	90460-64066	B - 7
8BD-77352-60	D - 10	526-82579-00	E - 8	8BD-W7726-00	D - 11		E - 13	90338-18176	D - 14	90461-06080	B - 12
8V0-77387-00	D - 13	8BD-82590-00	E - 8	8E3-W8291-01	E - 7	90201-06043	E - 3	90338-21075	B - 5	90464-16039	B - 8
81X-77511-00	D - 14	87S-8259A-00	B - 9	8BD-W8293-02	E - 11	90201-06071	C - 13	90338-40099	C - 4		C - 3
8AF-77512-00	D - 14	8AD-82720-00	E - 7	90101-06348	D - 2	90201-06380	D - 11	90386-07152	B - 14	90464-48226	D - 15
8AF-77513-00	D - 14	8BE-82917-00	E - 11		D - 4	90201-06727	B - 7	90387-057W5	B - 14	90465-08028	C - 4
8R4-77513-00	D - 14	8AU-82970-02	E - 11	90101-06534	C - 14	90201-06747	D - 4		E - 12		C - 9
84A-77531-01	D - 14	80V-83510-20	E - 4	90101-08005	C - 8	90201-077F5	B - 14		E - 13		E - 5
8Y1-77541-00	D - 14	4R0-83517-00	E - 4	90101-08374	D - 5		E - 12	90387-06027	D - 11		E - 8
8Y1-77554-00	D - 14	8G6-83523-00	E - 4	90101-10314	D - 6		E - 13	90387-06299	E - 3	90465-08333	B - 8
84R-77592-00	D - 14	8V7-83536-40	E - 4	90101-10357	D - 9	90201-08093	D - 4	90387-062N2	B - 6	90465-10189	C - 15
8R4-77595-01	D - 14	8Y8-83550-00	E - 4	90102-08027	C - 6	90201-083A8	D - 2	90387-066K1	B - 4	90465-10313	B - 4
80J-77596-00	D - 14	85G-83663-00	E - 7	90102-08028	C - 6	90201-08624	B - 6	90387-066N1	E - 6	90467-07055	B - 7
8Y1-77711-00	E - 2	803-83912-00	E - 7	90102-12030	C - 7	90201-08681	D - 2	90387-08224	C - 7	90467-08017	C - 3
81U-77711-90	E - 2	802-83913-00	E - 7	90105-06556	B - 4	90201-086A3	D - 8	90387-08262	C - 7		C - 10
8R4-77712-00	E - 2	8R6-83928-00	E - 7	90105-08688	C - 9		D - 14	90387-082N1	B - 6		C - 11
8U0-77721-00	E - 2	8E3-83930-01	E - 7		C - 10	90201-08784	C - 11	90387-08496	D - 5	90467-09026	C - 3
8R4-77740-00	E - 2	437-83936-01	E - 7	90109-08559	D - 2	90201-10149	D - 4	90387-08497	D - 5		C - 10
87A-77741-00	E - 2	8H8-83950-01	E - 7	90109-105E7	C - 6	90201-10321	C - 2	90387-08508	D - 5		C - 11
8K2-77741-00	E - 2	85G-83956-00	E - 7	90109-10771	D - 4	90201-122H1	B - 15	90387-087W7	B - 14	90467-11009	B - 7
87A-77742-00	E - 2	8R6-8399F-00	E - 7	90119-05071	B - 7		D - 8		E - 13	90467-11028	C - 10
8K4-77742-00	E - 2	8G9-84310-00	E - 5	90119-06097	D - 5	90201-12749	D - 6	90387-106L3	D - 5		C - 11
87A-77743-00	E - 2	8A7-84312-00	E - 5	90119-06108	B - 4	90202-08205	B - 14	90387-197E9	D - 8	90467-11032	B - 7
87A-77744-00	E - 2	8V0-84314-10	E - 5	90119-08008	D - 2		E - 12	90387-200F1	D - 8	90468-02025	B - 5
87A-77745-00	E - 2	8A7-84320-00	E - 5		D - 5		E - 13	90387-206L2	D - 5		B - 7
8BC-77761-00	D - 11	8A5-84331-00	E - 5	90151-06010	D - 4	90206-11016	B - 6	90387-260W3	B - 15	90468-05176	E - 5
87S-77761-10	D - 11	8A5-84332-00	E - 5	90154-06035	E - 3	90206-20037	C - 8	90389-28032	B - 14	90468-16099	D - 13
8BD-77762-00	D - 13	8AD-84359-00	E - 5	90157-05027	E - 7	90208-20008	D - 7		E - 12	90480-12012	E - 2
8BE-77762-00	C - 4	8T7-84366-00	E - 5	90157-05114	E - 7	90209-24183	B - 3		E - 13	90480-16422	E - 8
8BD-77762-21	D - 13	807-84374-00	E - 5	90159-05129	E - 3	90210-06006	D - 9	90389-40029	B - 14	90480-40047	C - 4
8Y1-77762-70	E - 2	8A7-84397-01	E - 5	90159-05130	E - 3	90210-08002	D - 9		E - 12	90480-53313	E - 2
8Y0-77762-90	C - 4	8K4-84710-00	E - 6	90164-05007	D - 11	90210-10004	D - 9		E - 13	90501-02217	B - 5
8M7-77767-00	D - 12	8K4-84711-00	E - 6	90170-10186	C - 8	90215-10155	C - 6	90430-04004	B - 5	90501-08214	B - 9
82H-81313-M0	E - 3	838-84714-01	E - 6	90170-16425	B - 3	90240-08068	C - 14	90430-31003	C - 3	90501-083J8	C - 3
81L-81314-M0	E - 3	8K4-84718-00	E - 6	90170-20211	D - 7	90240-12115	D - 5	90445-083K9	B - 7	90501-08443	B - 9
82M-81910-A0	E - 8	8K4-84721-00	E - 6	90175-08021	D - 13	90249-03017	C - 10	90445-084K0	B - 7	90501-20130	C - 10
4J2-82131-01	D - 13	87M-84723-00	E - 6	90176-06038	B - 13		C - 11	90445-095K5	C - 11		C - 11
86B-82310-10	E - 8	86R-85110-00	E - 9	90179-10279	C - 2	90249-06009	C - 14	90445-097J9	C - 10	90501-554E8	B - 14
83Y-82318-00	E - 8	80F-85115-00	E - 9		D - 6	90249-06012	C - 14	90445-111H4	C - 11	90506-06083	C - 9
89L-82318-00	E - 7	81G-85130-00	E - 9	90183-05013	D - 14	90249-12113	D - 6	90445-113K5	C - 10	90506-06261	B - 7
8BD-82318-00	E - 11	81L-85520-M0	E - 3	90185-08055	C - 6	90267-48014	E - 11	90445-113K6	C - 11	90506-06262	B - 7

NUMERICAL INDEX

PART NO.	GRID NO.	PART NO.	GRID NO.	PART NO.	GRID NO.	PART NO.	GRID NO.	PART NO.	GRID NO.	PART NO.	GRID NO.
90506-16494	B - 11	92907-06600	B - 13	95301-06700	B - 13	95827-06012	C - 9	98507-05016	B - 5		
90506-20074	B - 11		B - 14	95307-05600	B - 5	95827-06025	B - 6		E - 2		
90508-08353	C - 10		C - 9		D - 11	95827-06030	B - 6	98507-05020	B - 4		
	C - 11		D - 4		E - 4	95827-08014	D - 7	98507-05025	B - 7		
90508-10715	C - 10		E - 12	95307-06600	B - 13	95827-08016	C - 5	98507-05030	B - 4		
	C - 11	92907-08100	C - 5		E - 6		D - 15	98507-06016	C - 9		
90508-29601	C - 14		D - 14		E - 8	95827-08020	B - 11	98507-06020	B - 6		
90508-29602	C - 14	92907-08200	C - 2	95307-06700	C - 14		D - 2		D - 4		
90508-40080	B - 15		D - 13	95307-08800	C - 5	95827-08025	D - 6	98602-04008	B - 9		
90508-99331	D - 6	92907-08600	B - 15		D - 14	95827-08030	B - 12	98707-04016	E - 2		
90508-99332	D - 6		C - 5	95307-10700	C - 8	95827-08035	B - 2	98907-04008	B - 5		
90508-99649	D - 6		C - 6		D - 9	95827-08055	C - 8	98907-05012	D - 14		
90508-99650	D - 6		C - 14	95307-12600	D - 8	95827-08065	D - 9	98907-05016	D - 8		
91401-20015	C - 6		D - 8	95307-12900	C - 7	95827-08080	B - 12	98907-06016	D - 14		
	C - 14		D - 14	95607-06100	D - 11	95827-08260	D - 4	98907-06030	C - 4		
91401-25020	C - 8	92907-16100	B - 3	95607-08200	C - 6	95827-10080	D - 5	98907-08016	C - 5		
91401-25025	D - 8		B - 14		D - 4	97007-05035	D - 4	98907-08020	D - 14		
91401-30020	D - 5		E - 12	95612-05100	E - 13	97007-06010	D - 9	99001-04600	E - 7		
91401-30025	C - 7	92990-05200	E - 7	95617-05100	B - 14	97007-06020	D - 4	99009-10400	B - 6		
	D - 6	92990-06600	E - 8		E - 12	97007-06025	B - 13	99009-20400	D - 2		
91609-25032	C - 10	93101-10001	B - 6	95701-05300	E - 7	97007-06035	D - 4	99009-42500	D - 2		
	C - 11	93102-20010	D - 8	95707-04300	E - 2	97007-08016	D - 14	99009-47500	D - 2		
91609-30010	C - 15	93102-25081	D - 8	95707-04500	E - 10	97007-08020	D - 9				
91609-30016	C - 10	93102-25183	B - 3	95707-05300	B - 4	97007-08055	C - 7				
	C - 11	93102-30326	B - 3		B - 7	97007-08070	C - 7				
91609-40040	D - 2	93104-29072	B - 6		D - 4	97017-06030	B - 14				
91808-22019	B - 6	93210-19309	B - 9	95707-05500	E - 9		E - 12				
91A20-05045	C - 3	93306-00416	D - 7	95707-06300	C - 13	97022-05035	E - 13				
91A20-05090	C - 10	93306-00444	D - 2		D - 4	97027-05035	B - 14				
91A20-05140	C - 10	93306-20469	D - 2	95707-06500	B - 7		E - 12				
91A30-05024	C - 3	93306-20582	B - 15		C - 4	97027-08016	B - 15				
91A30-05045	C - 3	93306-30407	D - 8		D - 11		D - 15				
91A30-05065	C - 3	93306-30555	B - 3		D - 14	97027-08020	C - 11				
92901-06100	B - 13	93306-30623	B - 3	95707-08300	C - 6		D - 14				
92902-04100	B - 9	93310-218A6	B - 3		C - 11	97027-08025	D - 8				
92907-04600	E - 2	93310-424E8	B - 3		D - 5	97027-08045	D - 5				
92907-05100	B - 4	93430-02001	C - 10		D - 15	97027-08250	D - 5				
	B - 5		C - 11	95707-08500	C - 2	97602-04108	E - 3				
	D - 11	93440-25100	B - 15	95707-10300	C - 8	97602-04112	E - 3				
	E - 4	93450-20026	B - 3	95707-10500	C - 2	97701-30712	E - 7				
92907-05200	D - 11	93505-32002	B - 5	95807-06008	C - 11	97701-40130	E - 6				
92907-05600	B - 4	93603-22028	B - 6	95807-06012	C - 4	97706-30620	E - 11				
	B - 7	93607-44190	B - 14		E - 8	97707-30630	E - 11				
92907-06100	B - 6		E - 12	95807-08012	B - 13	97707-60510	B - 7				
	B - 13		E - 13	95807-08016	B - 13	97880-06040	E - 8				
	E - 6	94580-01044	D - 8		D - 14	98502-04040	B - 9				
92907-06200	C - 9	94702-00195	B - 2	95807-10014	C - 2	98507-04016	E - 10				
92907-06600	B - 6	94709-00195	B - 2	95807-10020	C - 2	98507-04018	B - 5				